



fourstargroup

ASSEMBLY INSTRUCTIONS







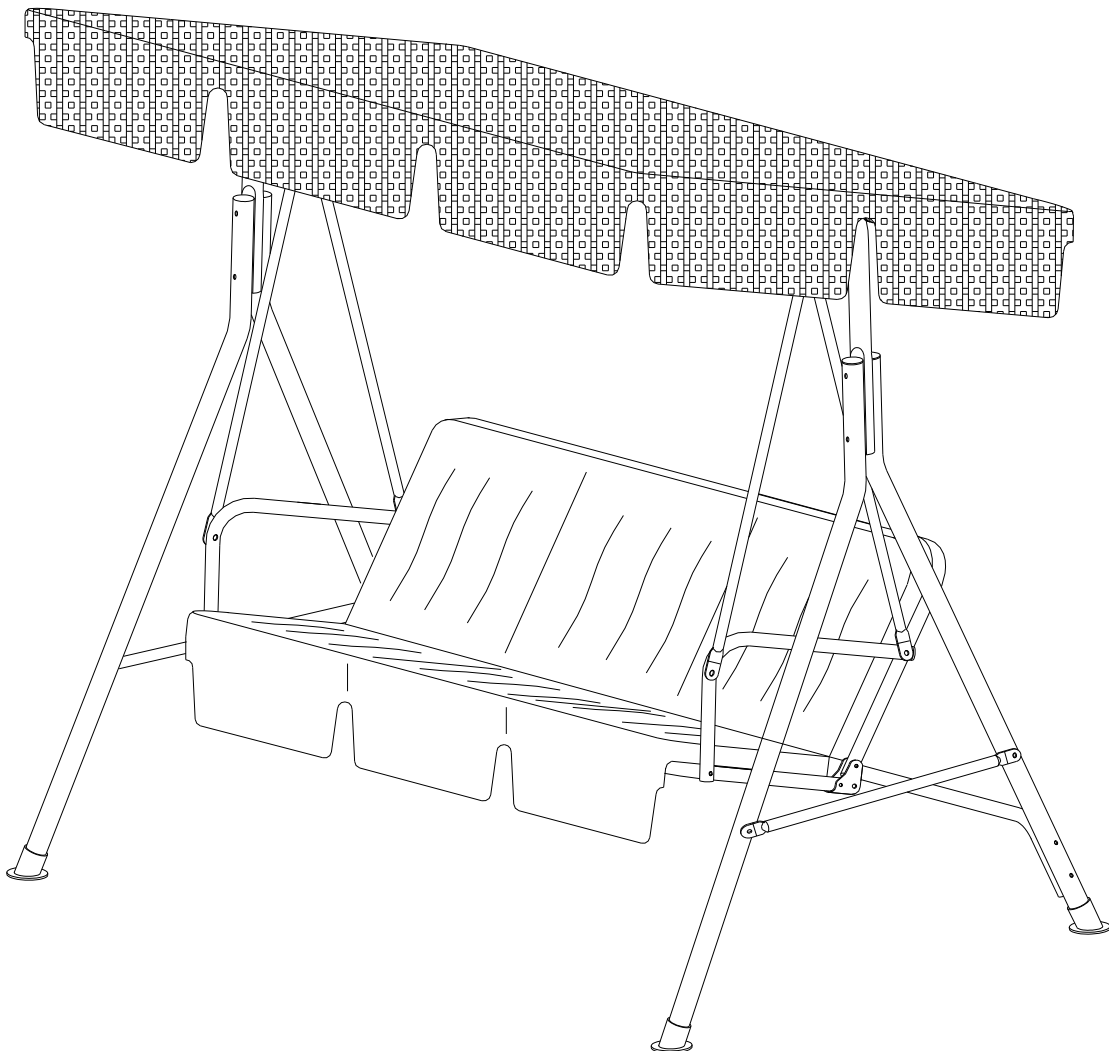



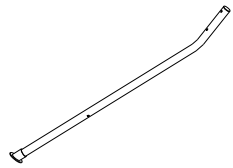
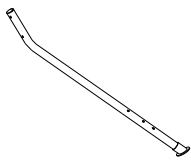

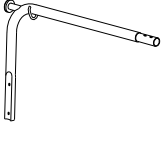

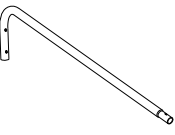
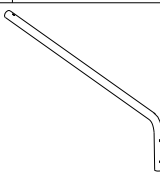

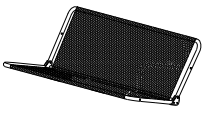

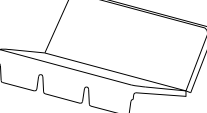

3-SEAT CUSHIONED SWING WITH CANOPY

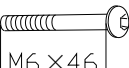
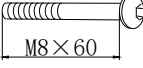
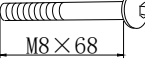
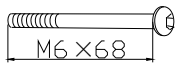
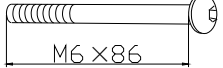
12505483FR /12505483FG

**INSTRUCCIONES DE MONTAJE
HAMACA DE 3 ASIENTOS
CON TECHO DE LONA**

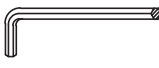
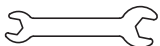

PART LIST/LISTA DE PARTES:

			
A 2	B 2	C 1	D 1
			
E 2	E1 4	F 1	G 1
			
H 2	I 2	J 1	K 2
			
L 2	M 1	N 1	O 1
			
P 2	Q 2	R 2	S 2
			
T 4	U 4	V1 15	V2 6
			
W1 15	W2 6	X 4	Y 2
			
Z1 15	Z2 6	AA 2	BB 1

WARNING :

HAVE AT LEAST 2 PEOPLE TO ASSEMBLE THE SWING. TOOLS ARE NOT INCLUDED. MAKE SURE THAT ALL THE NECESSARY PIECES ARE IN THE CARTON BEFORE STARTING THE ASSEMBLY.

ASSEMBLE THE SWING ON A FLAT AND SOLID SURFACE FREE FROM ANY OBJECT THAT MIGHT DAMAGE IT. IF YOU ASSEMBLE THE SWING ON A SOFT SURFACE, IT WILL BE UNSTABLE.

ADVERTENCIA :

TENER UN MÍNIMO DE 2 PERSONAS PARA MONTAR LA HAMACA. LAS HERRAMIENTAS NO ESTÁN INCLUIDAS.

ASEGÚRESE DE QUE TODAS LAS PIEZAS NECESARIAS ESTÉN EN LA CAJA DE CARTÓN ANTES DE INICIAR EL MONTAJE.

MONTAR LA HAMACA SOBRE UNA SUPERFICIE PLANA Y SÓLIDA LIBRE DE CUALQUIER OBJETO QUE PUEDA DAÑARLA. SI ARMA LA HAMACA SOBRE UNA SUPERFICIE BLANDA, ÉSTA SERÁ INESTABLE.

ASSEMBLY /MONTAJE :

STEP/PASO 1

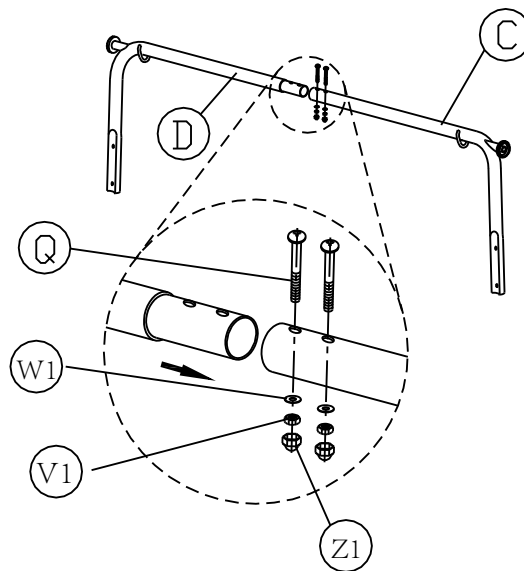

C × 1
D × 1
Q × 2
W1 × 2
V1 × 2
Z1 × 2

STEP/PASO 2

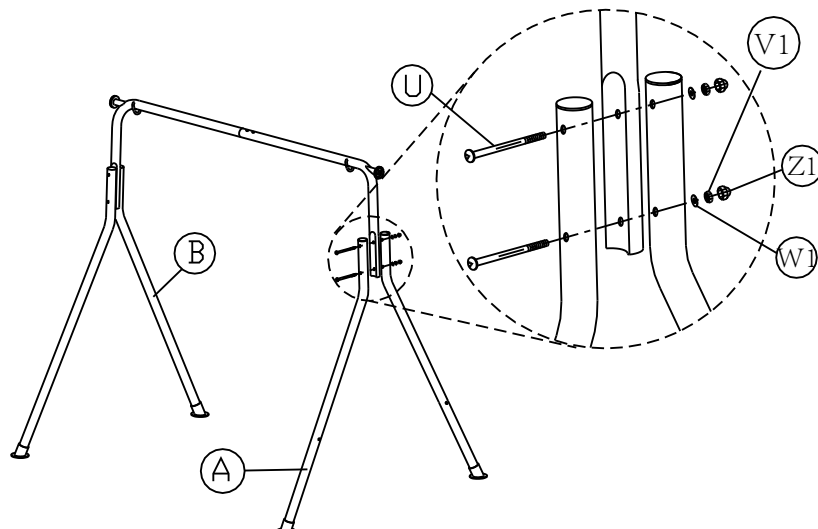

A × 2
B × 2
U × 4
W1 × 4
V1 × 4
Z1 × 4

STEP/PASO 3

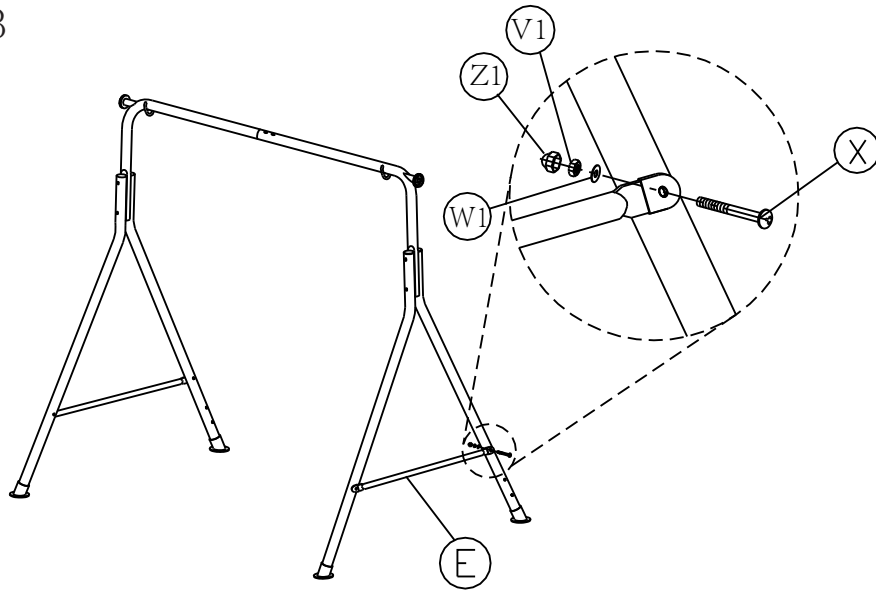

- E × 2
- X × 4
- W1 × 4
- V1 × 4
- Z1 × 4

STEP/PASO 4

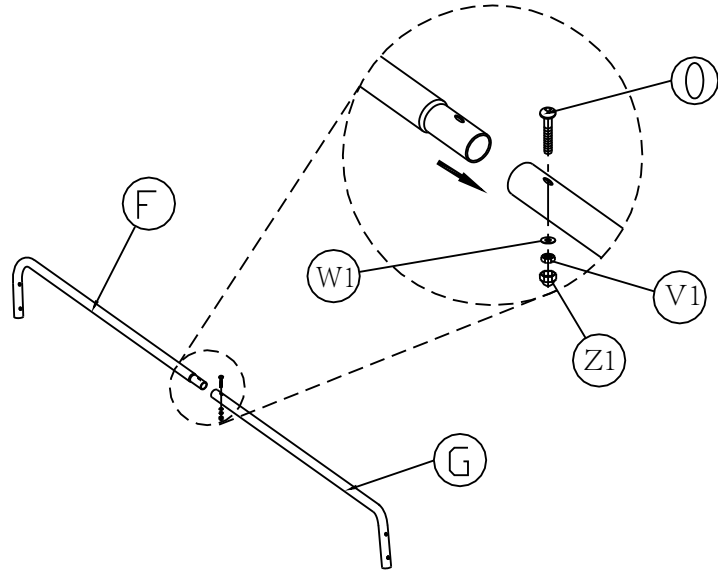

- F × 1
- G × 1
- W1 × 1
- V1 × 1
- Z1 × 1

STEP/PASO 5

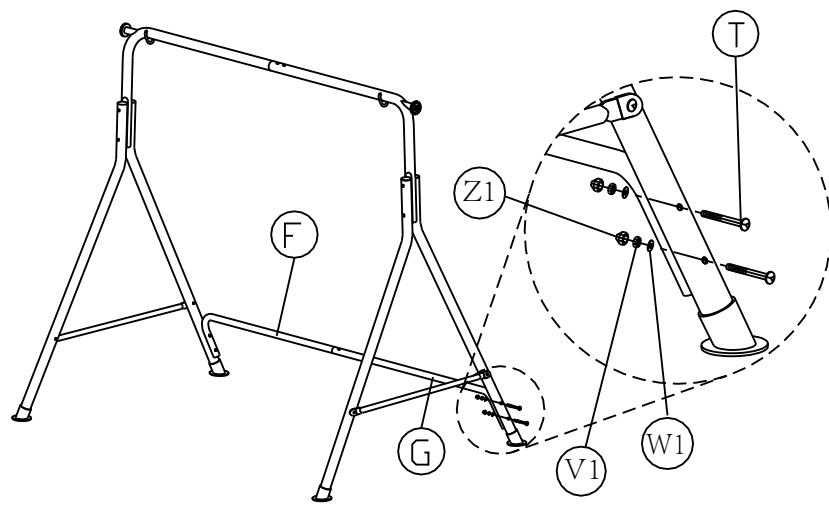

- T × 4
- W1 × 4
- V1 × 4
- Z1 × 4

STEP/PASO 6

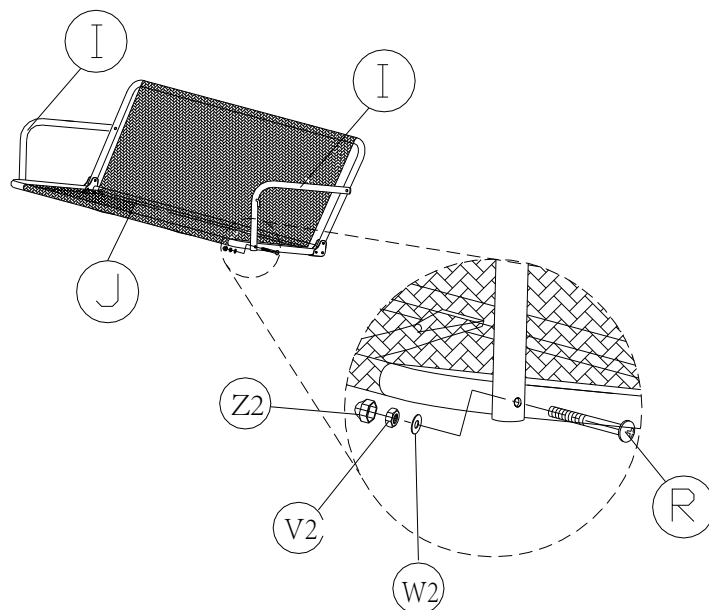

- I × 2
- J × 1
- R × 2
- W2 × 2
- V2 × 2
- Z2 × 2

STEP/PASO 7

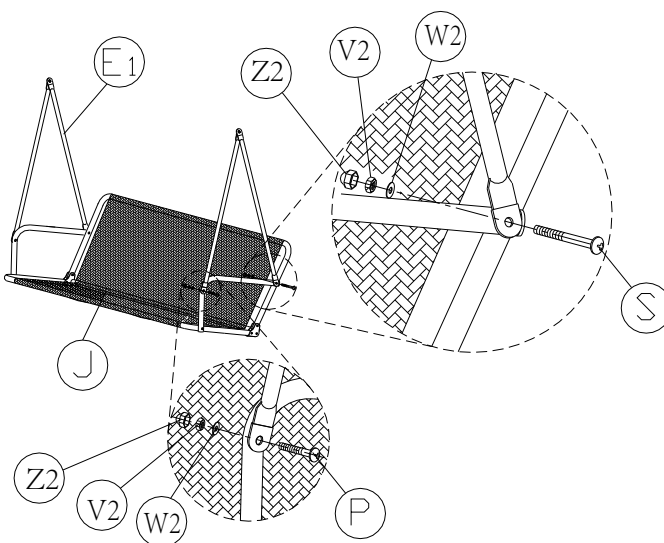

- E1 × 4
- S × 2
- P × 2
- W2 × 2
- V2 × 2
- Z2 × 2

STEP/PASO 8

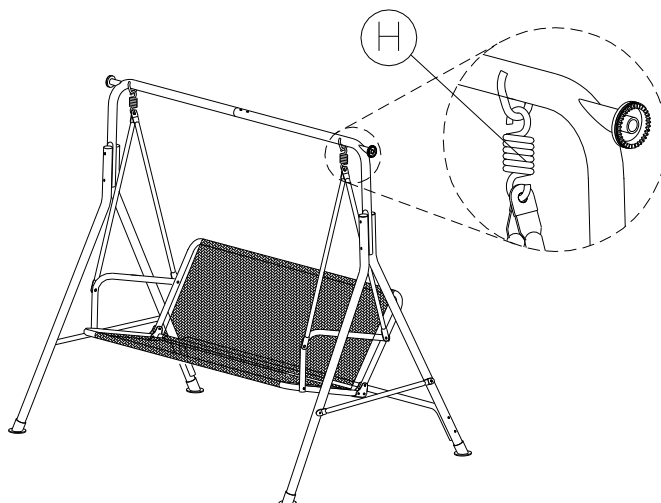

- H × 2

STEP/PASO 9

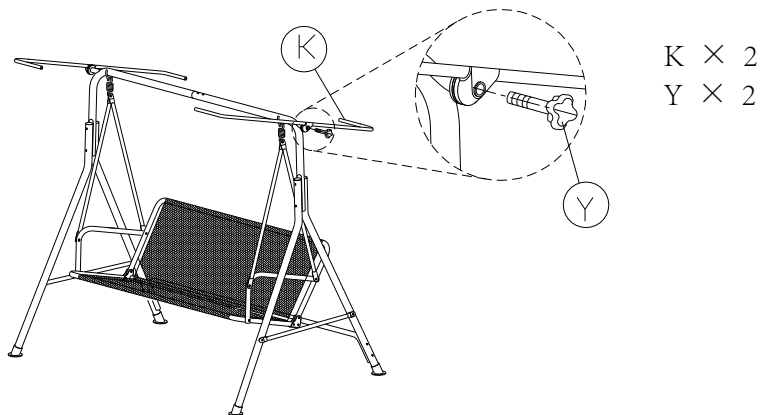

STEP/PASO 10

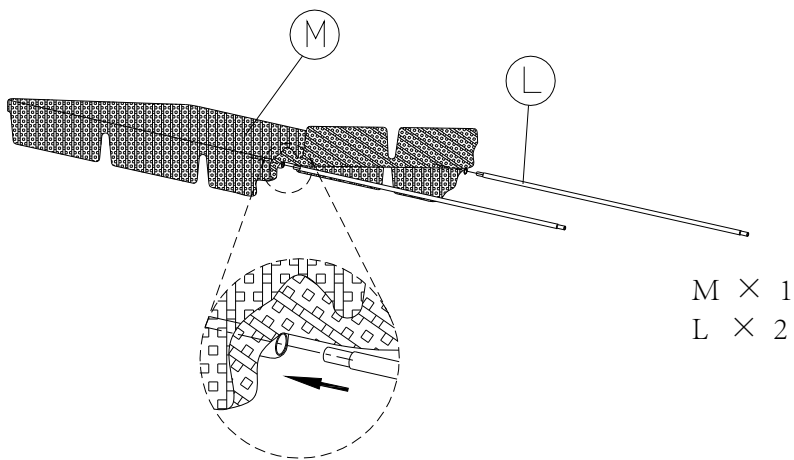

STEP/PASO 11

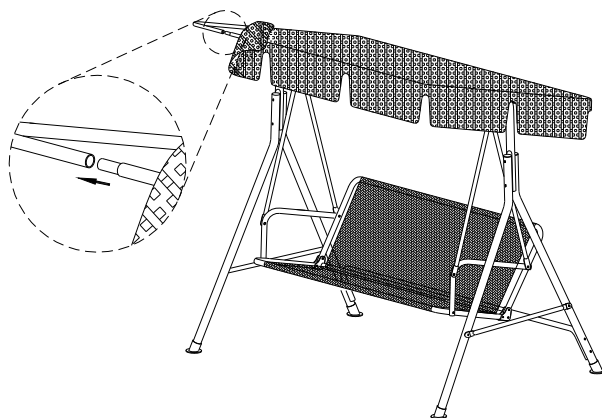

STEP/PASO 12

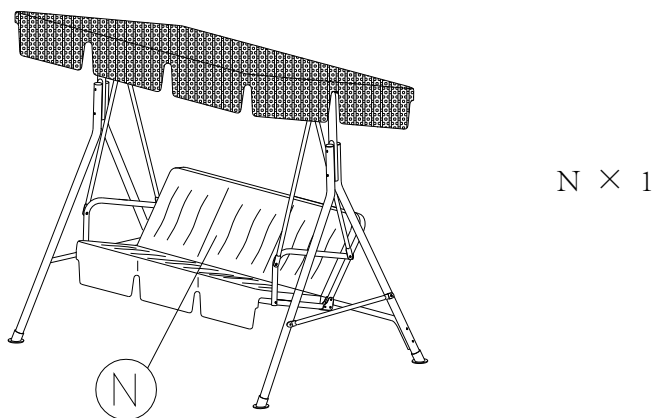

WARNING:

1. Keep away from fire as well as from flammable objects.
2. When swinging, take especial care of the following:
 - a) Make sure to put the swing on a flat and solid surface.
 - b) Do not put your arms and legs between the frame and the seats. Risk of injury!
 - c) Do not put objects directly behind or in front of the swing
 - d) When swinging, make sure that the swing is firmly secured. The maximum pendulum angle is twenty Degree. Excessive movement while using the swing can cause the swing to tip over and lead to injury.
3. Maximum weight: 660 lbs.
4. Do not leave a child swinging without adult supervision
5. At least once per month, make sure that all the screws are well tighten and that the swing is stable.
6. Cover the swing when raining or when windy.
7. Take down the swing in the fall to protect it from the winter weather.

ADVERTENCIA :

1. Mantener la hamaca alejada del fuego, así como de objetos inflamables.
2. Al usar la hamaca, tener especial cuidado de lo siguiente:
 - a) Asegúrese de poner la hamaca sobre una superficie plana y sólida.
 - b) No ponga sus brazos y piernas entre el marco y los asientos. ¡Peligro de lesiones!
 - c) No coloque objetos directamente detrás o delante de la oscilación
 - d) Al usar la hamaca, asegúrese de que el columpio esté firmemente asegurado. El ángulo máximo del péndulo es veinte grados. El movimiento excesivo durante el uso de la oscilación puede causar que el columpio se vuelque y ocasionar daños personales.
3. Peso máximo: 660 lbs.
4. No deje a los niños balanceándose solos y sin supervisión de un adulto
5. Al menos una vez al mes, asegúrese de que todos los tornillos estén bien apretados y que la oscilación sea estable.
6. Cubrir el columpio cuando llueve o cuando hay viento.
7. Desarme la hamaca en el otoño para protegerla del clima invernal.

Do you have any questions? Missing small parts or hardware?
If you need assistance with the assembly of your 3 SEAT CUSHIONED SWING WITH CANOPY, please e-mail our Customer Service Department at: support@fourstari.com or call us at (508) 473-7688 or (800) 639-3803

Please include the following information in your email:

- Where item was purchased
- Item, model, style or SKU number listed on instructions or box
- Part number, description of the part and quantity needed

This information will help us get the proper part to you faster

¿Tiene alguna pregunta? ¿Faltan piezas o accesorios pequeños?
Si necesita ayuda para ensamblar su HAMACA DE TRES ASIENTOS CON TECHO DE LONA envíenos un correo electrónico a nuestro Departamento de atención al cliente: ayuda@fourstari.com o llámenos al (508) 473-7688 o al (800) 639-3803

Incluya la siguiente información en el correo electrónico:

- Dónde compró el producto
- El número de artículo, SKU, estilo, modelo o producto que aparece en las instrucciones o la caja
- El número y descripción de la pieza y la cantidad que necesita

Esta información nos ayudará a enviarle la pieza correcta con mayor rapidez

SIZE: 21L X 29.7H(CM)

 fourstargroup	ARTWORK NO.	ITEM DESCRIPTION	MDSER	DESIGNER	DATE
	SZ16FRS12505483FR_MAN	Xxxx Xxxxxx	Sean	Miumiu	10/22

This proprietary artwork and concepts are copyright designs of Fourstar Group Inc. 2016. No part of this artwork may be reproduced or transmitted in any form without express written consent. © Fourstar Group Inc. All Rights Reserved.