



fourstargroup



MODEL: 11228832 / MODELO: 11228832
THREE TIER SIX CUBE STORAGE
LIBRERO DE TRES ESTANTES
CON 6 CAJAS ORGANIZADORAS

BEFORE YOU BEGIN, PLEASE READ ASSEMBLY INSTRUCTIONS CAREFULLY. FOLLOW THEM STEP BY STEP.

CAUTION:

1. ADULT SUPERVISION IS REQUIRED DUE TO SMALL PARTS. CARE SHOULD BE TAKEN IN THE UNPACKING AND ASSEMBLY OF THE PRODUCT.
2. ASSEMBLE ON SOFT SURFACES TO PREVENT DAMAGE TO THE PRODUCT FINISH.
3. MAKE SURE ALL PARTS ARE INCLUDED BEFORE ASSEMBLY.
4. PLACE THREE TIER SIX CUBE STORAGE ON FLAT, LEVEL SURFACE. THREE TIER SIX CUBE STORAGE WILL NOT BE STABLE ON HIGH PILE CARPETING OR OUT OF LEVEL SURFACES. NOT FOR USE ON HIGH PILE CARPETING OR OTHER SIMILAR SURFACES.

ASSEMBLY TOOLS REQUIRED
SCREWDRIVER

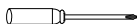

ANTES DE EMPEZAR, POR FAVOR LEA LAS INSTRUCCIONES DE MONTAJE. SÍGALAS PASO A PASO.

PRECAUCIÓN:



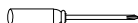

1. SE REQUIERE LA SUPERVISIÓN DE UN ADULTO DEBIDO A LA EXISTENCIA DE PIEZAS PEQUEÑAS. DEBE TENER CUIDADO AL DESEMPACAR Y DURANTE EL MONTAJE DE ESTE PRODUCTO.
2. ENSÁMBLELO SOBRE SUPERFICIES SUAVES PARA EVITAR DAÑAR EL ACABADO DEL PRODUCTO.
3. ASEGÚRESE DE QUE TODAS LAS PARTES ESTÉN INCLUIDAS ANTES DE COMENZAR.
4. COLOQUE EL LIBRERO DE TRES ESTANTES CON 6 CAJAS ORGANIZADORAS EN UNA SUPERFICIE PLANA Y NIVELADA. EL LIBRERO DE TRES ESTANTES CON 6 CAJAS ORGANIZADORAS NO SERÁ ESTABLE SOBRE UNA ALFOMBRA ALTA O SUPERFICIES NO NIVELADAS. NO DEBE USARSE SOBRE ALFOMBRAS ALTAS O SUPERFICIES SIMILARES.













HERRAMIENTAS NECESARIAS:
DESTORNILLADOR



HARDWARE & PART LIST

LISTA DE ACCESORIOS Y PARTES

NO	PARTS LIST LISTA DE PARTES Y ACCESORIOS	QTY/CNT
A	TOP SHELF ESTANTE SUPERIOR 	1 PC 1 PZ
B	2nd AND 4th SHELF SEGUNDO Y CUARTO ESTANTE 	2 PCS 2 PZS
C	3rd SHELF TERCER ESTANTE 	1 PC 1 PZ
D	BOTTOM SHELF ESTANTE INFERIOR 	1 PC 1 PZ

E	SHORT SPINDLE EJE CORTO		4 PCS 4 PZS
F	LONG SPINDLE EJE LARGO		12 PCS 12 PZS
G	FOOT PATA		4 PCS 4 PZS
H	CROSS BAR TRAVESAÑO		4 PCS 4 PZS
I	BACK PANEL PANEL TRASERO		2 PCS 2 PZS
J	BIN CAJÓN		6 PCS 6 PZS
K	WOODEN DOWEL CLAVIJA DE MADERA		4 PCS 4 PZS
L	LARGE SCREW TORNILLO LARGO		4 PCS 4 PZS
M	SMALL SCREW TORNILLO CORTO		8 PCS 8 PZS
1	CABLE TIE CABLE DE AMARRE		2 PCS 2 PZS
2	WALL PLUG TORNILLO CON OJETE		2 PCS 2 PZS
3	WALL PLUG TARUGO		2 PCS 2 PZS

ASSEMBLY INSTRUCTIONS

INSTRUCCIONES DE ASAMBLEA

STEP 1

STEP 1-1

PLACE THE TOP SHELF (A) SURFACE FACE DOWN ON A SOFT CLOTH/BLANKET IN ORDER TO PROTECT SURFACE. SCREW SHORT SPINDLES (E) INTO 4 CORNERS.

STEP 1-2

PUT 2ND SHELF (B) ON COMPLETED STEP 1-1, SCREW LONG SPINDLES (F) INTO 4 CORNERS. PUT DOWELS (K) INTO CROSS BARS (H) AND SCREW INTO MIDDLE HOLES ON SHELF (B) USING LARGE SCREWS (L).

STEP 1-3

PUT 3RD SHELF (C) ON COMPLETED STEP 1-2, SCREW LONG SPINDLES (F) INTO 4 CORNERS. ATTACH CROSS BARS (H) TO DOWELS (K) IN MIDDLE HOLES OF SHELF (C).

STEP 1-4

PUT 4TH SHELF (B) ON COMPLETED STEP 1-3, SCREW LONG SPINDLES (F) INTO 4 CORNERS. USE LARGE SCREWS (L) TO ATTACH CROSS BARS (H) TO 4TH SHELF (B).

STEP 1-5

PLACE BOTOM SHELF (D) ON COMPLETED STEP 1-4 AND SCREW IN 4 FEET (G).

STEP 1-6

TURN OVER COMPLETED UNIT AS SHOWN.

PASO 1

PASO 1-1

COLOQUE EL ESTANTE SUPERIOR (A) BOCA ABAJO EN UN PAÑO SUAVE PARA PROTEGER EL ACABADO, ATORNILLE LOS EJES CORTOS (E) EN LAS 4 ESQUINAS.

PASO 1-2

COLOQUE EL ESTANTE # 2 (B) A ESTOS EJES. ATORNILLE LOS EJES LARGOS (F) A LAS 4 ESQUINAS. COLOQUE LAS CLAVIJAS (K) A LOS TRAVESAÑOS (H) E INSÉRTELOS EN LOS AGUJEROS MEDIOS DEL ESTANTE (B) USANDO TORNILLOS LARGOS (L).

PASO 1-3

COLOQUE EL TERCER ESTANTE (C) AL PASO 1-2 COMPLETO, ATORNILLE EJES LARGOS (F) EN LAS 4 ESQUINAS. ADJUNTE TRAVESAÑO (H) Y CLAVIJAS (K) EN LOS AGUJEROS MEDIOS DEL ESTANTE (C).

PASO 1-4

COLOQUE EL CUARTO ESTANTE (B) AL PASO 1-3 COMPLETO, ATORNILLE EJES LARGOS (F) EN LAS 4 ESQUINAS. USE TORNILLOS LARGOS (L) Y ADJUNTE A LOS TRAVESAÑOS (H) E INSÉRTELOS EN LOS AGUJEROS MEDIOS DEL ESTANTE (B).

PASO 1-5

COLOQUE EL ESTANTE INFERIOR (D) AL PASO 1-4 COMPLETO, ATORNILLE LAS PATAS (G).

PASO 1-6

DE VUELTA LA UNIDAD COMO SE MUESTRA.

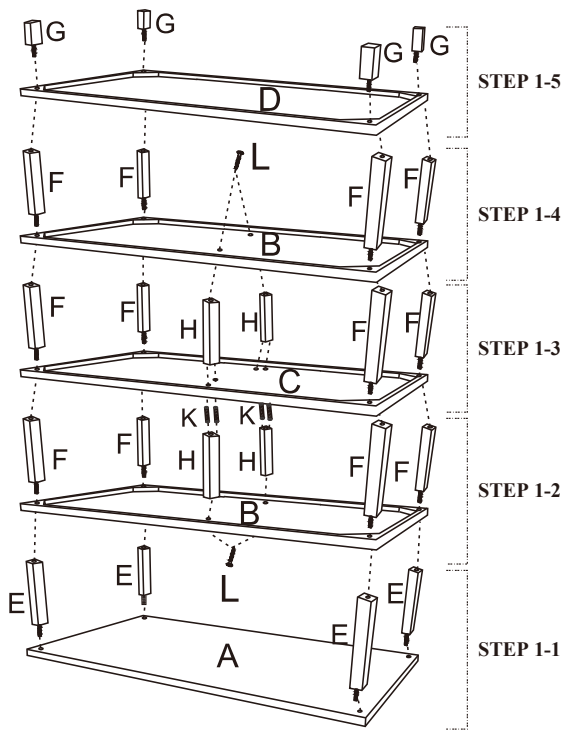

STEP 2

ATTACH THE BACK PANELS (I) TO THE BACK FRAME BY USING THE SMALL SCREWS (M) AS SHOWN.

PASO 2

ADJUNTE LOS PANELES TRASEROS (I) A LA PARTE TRASERA DEL MARCO USANDO TORNILLOS CORTOS (M) COMO SE MUESTRA.

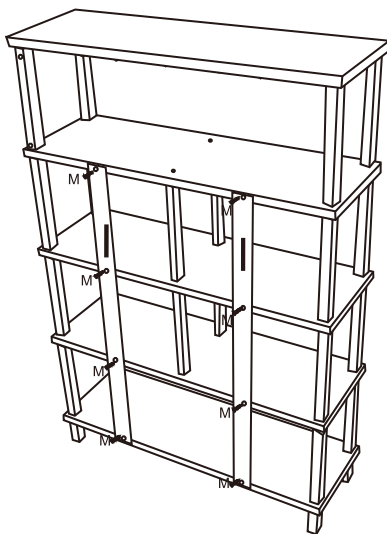

STEP 3

TURN AROUND AND INSERT BINS (J) TO THE SHELVES AS SHOWN.

PASO 3

ATTACH THE BACK PANELS (I) TO THE BACK FRAME BY USING THE SMALL SCREWS (M) AS SHOWN.

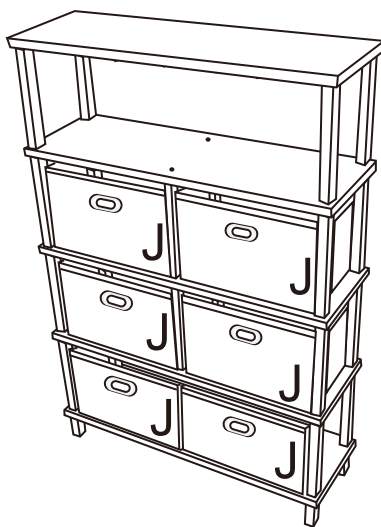

**PLEASE FOLLOW BELOW INSTRUCTION
TO PREVENT PRODUCT TIP OVER.**

**POR FAVOR SIGA LAS INSTRUCCIONES PARA
PREVENIR QUE EL PRODUCTO SE VUELQUE.**

**WALL
PARED**

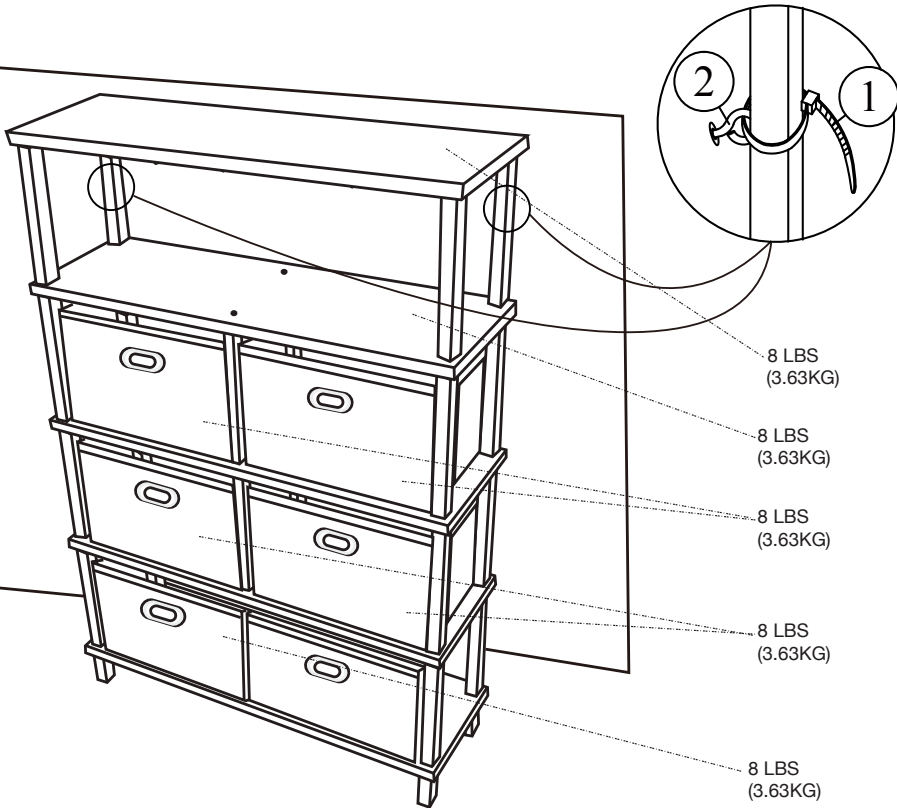

**Weight Maximum 40 lbs (18.1 kg)
Peso Maximo 40 lbs (18.1 kg)**

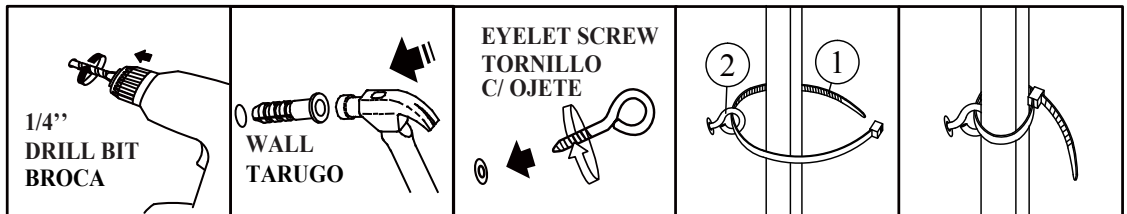

This unit is intended for use only with the products and maximum weights indicated. Use with other products or products heavier than the maximum weights indicated may result in instability causing possible injury. Furniture can tip over or break if improperly moved. Have a friend help to lift and carry the unit to it's new location.

Esta unidad está destinada sólo para su uso con los productos y pesos máximos indicados. Si usted utiliza esta mesa con otros productos o de los productos más pesados que el peso máximo indicado, puede causar inestabilidad y puede dar lugar a posibles lesiones. La mesa puede volcarse o romperse si es trasladada indebidamente. Se sugiere tener un amigo para que le ayude a levantar y transportar la mesa a su nueva ubicación.



**CAUTION: MAXIMUM LOADING
CAPACITY OF THIS TABLE IS 40 LBS.**

**DO NOT SIT, STAND,
LEAN, WALK OR JUMP ON TABLE!
FAILURE TO COMPLY WITH THIS
CAUTION COULD RESULT IN PERSONAL
INJURY AND/OR PROPERTY DAMAGE!**



**PRECAUCIÓN: LA CARGA MÁXIMA
DE ESTA MESA ES DE 40 LBS.**

**NO SENTARSE,
PARARSE, APOYARSE, CAMINAR O
SALTAR SOBRE LA MESA! EL
INCUMPLIMIENTO PUEDE RESULTAR
EN LESIONES PERSONALES Y / O
DAÑOS A LA PROPIEDAD!**

Do you have any questions? Missing small parts or hardware?
If you need assistance with the assembly of your
THREE TIER SIX CUBE STORAGE
please e-mail our Customer Service Department at:
support@fourstari.com or call us at **(800) 639-3803** or
(508) 473-7688 if calling locally from Massachusetts area

Please include the following information in your email:

- Where item was purchased
- Item, model, style or SKU number listed on instructions or box
- Part number, description of the part and quantity needed

This information will help us get the proper part to you faster

¿Tiene alguna pregunta? ¿Faltan piezas o accesorios pequeños? Si necesita ayuda para ensamblar su **LIBRERO DE TRES ESTANTES CON 6 CAJAS ORGANIZADORAS** envíenos un correo electrónico a nuestro Departamento de atención al cliente:

ayuda@fourstari.com o llámenos al **(800) 639-3803** o
(508) 473-7688 si llama desde la zona de Massachusetts

Incluya la siguiente información en el correo electrónico:

- Dónde compró el producto
- El número de SKU, estilo, modelo o producto que aparece en las instrucciones o la caja
- El número y descripción de la pieza y la cantidad que necesita

Esta información nos ayudará a enviarle la pieza correcta con mayor rapidez

SIZE: 35 L X 21.7H(CM)

 fourstargroup	ARTWORK NO.	ITEM DESCRIPTION	MDSER	DESIGNER	DATE
	SZ20VW11228832	Xxxx Xxxxxx	Lala	Miumiu	03/30

This proprietary artwork and concepts are copyright designs of Fourstar Group Inc. 2020. No part of this artwork may be reproduced or transmitted in any form without express written consent. © Fourstar Group Inc. All Rights Reserved.