

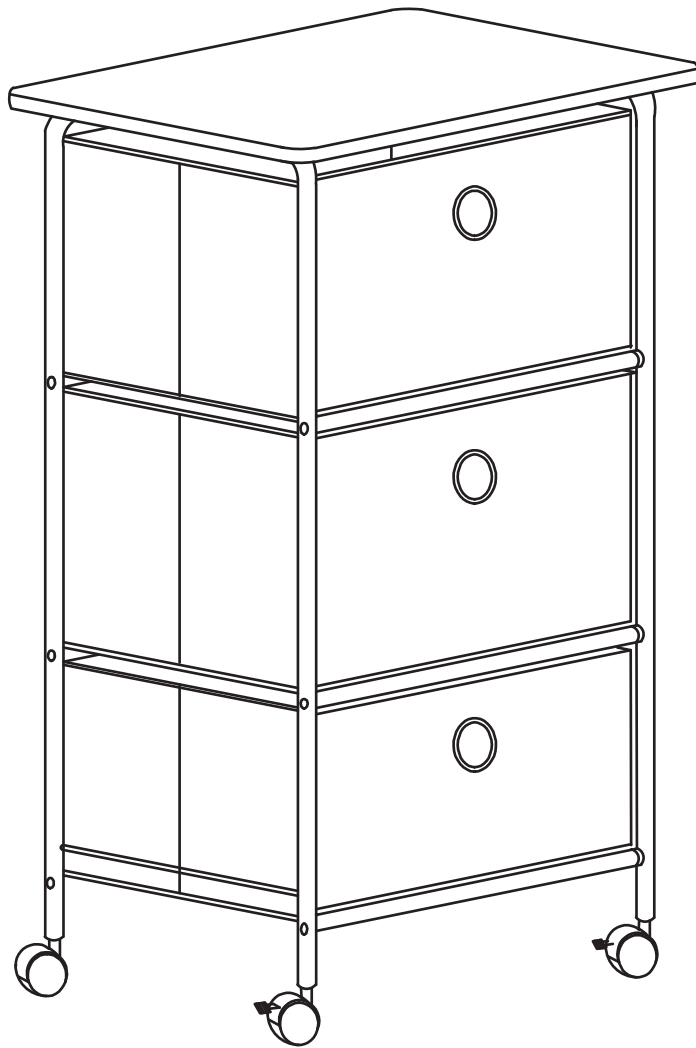











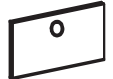

fourstargroup

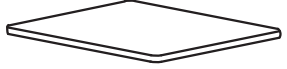

**MODEL: 11226507R**

**STORAGE SHELF 3 DRAWER**

# PARTS AND HAREWARE LIST

| NO | PARTS LIST  | QTY.   |
|----|---|--------|
| A  | LEG FRAME         | 2 PCS  |
| B  | WIRE SHELF        | 3 PCS  |
| C  | NON-WOVEN BIN     | 3 PCS  |
| D  | BOTTOM PLATE      | 3 PCS  |
| E  | TOP PANEL       | 1 PC   |
| F  | BOLT  BOH:30MM   | 12 PCS |
| G  | SCREW           | 4 PCS  |
| H  | PLASTIC WASHER  | 12 PCS |
| I  | ALLEN WRENCH    | 1 PC   |
| J  | WRENCH          | 1 PC   |
| K  | LOCKING CASTER  | 2 PCS  |
| L  | CASTER          | 2 PCS  |

# ASSEMBLY INSTRUCTIONS

BEFORE YOU BEGIN, PLEASE READ ASSEMBLY INSTRUCTIONS CAREFULLY, FOLLOW THEM STEP BY STEP.

## CAUTION:

1. ADULT SUPERVISION IS REQUIRED DUE TO SMALL PARTS. CARE SHOULD BE TAKEN IN THE UNPACKING AND ASSEMBLY OF THE PRODUCT.
2. ASSEMBLE ON SOFT SURFACE TO PREVENT DAMAGE TO THE PRODUCT FINISH.
3. MAKE SURE ALL PARTS ARE INCLUDED BEFORE ASSEMBLY.

## ASSEMBLY TOOL REQUIRED: PHILIPS SCREWDRIVER

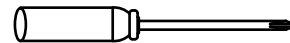

## STEP 1

ATTACH WIRE SHELF (B) TO THE LEG FRAME (A) USING BOLT (F) AND PLASTIC WASHER (H) WITH ACCESSARY ALLEN WRENCH (J) AS SHOWN.

**IMPORTANT:** DO NOT TIGHTEN THE BOLTS AT THIS TIME

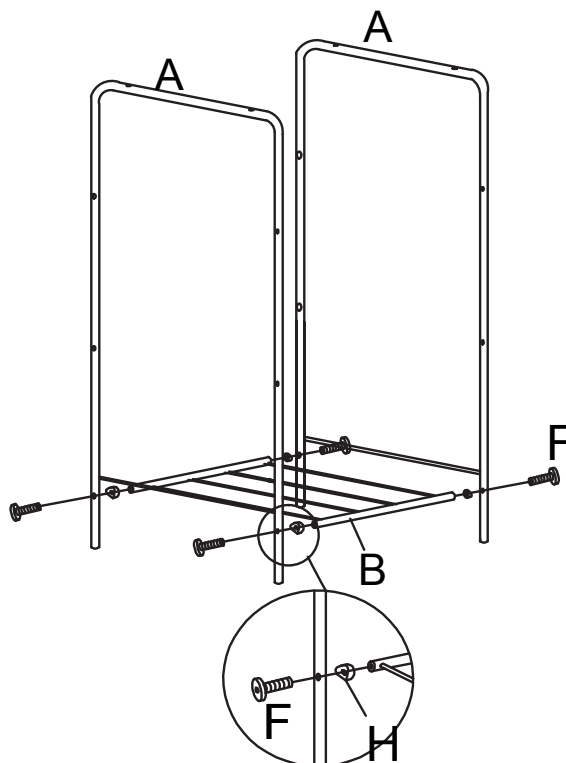

## STEP 2

REPEAT STEP 1, ATTACH WIRE SHELF (B) TO THE LEG FRAME (A) USING BOLT (F) AND PLASTIC WASHER (H) WITH ACCESSARY ALLEN WRENCH (J) AS SHOWN.

**IMPORTANT:** DO NOT TIGHTEN THE BOLTS AT THIS TIME

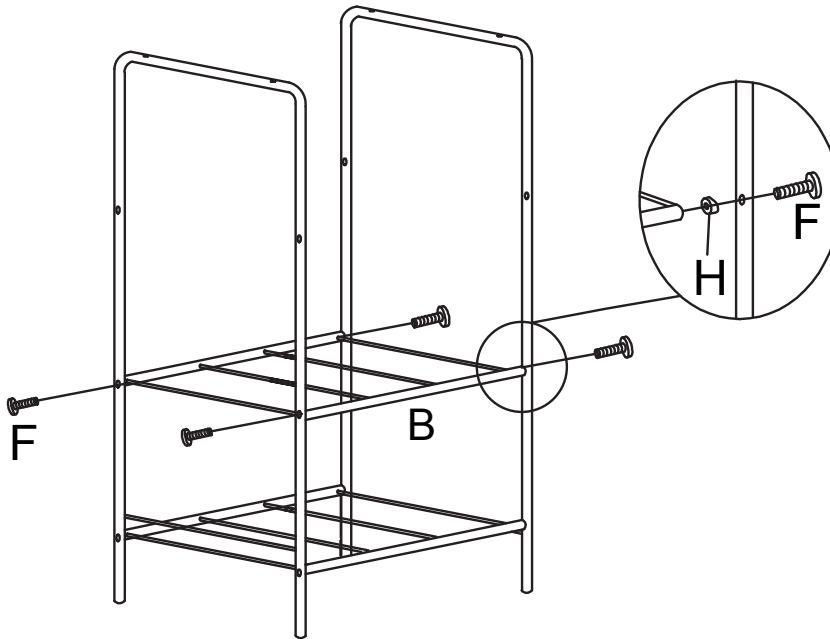

## STEP 3

REPEAT STEP 1, ATTACH WIRE SHELF (B) TO THE LEG FRAME (A) USING BOLT (F) AND PLASTIC WASHER (H) WITH ACCESSARY ALLEN WRENCH (J) AS SHOWN.

**IMPORTANT:** DO NOT TIGHTEN THE BOLTS AT THIS TIME

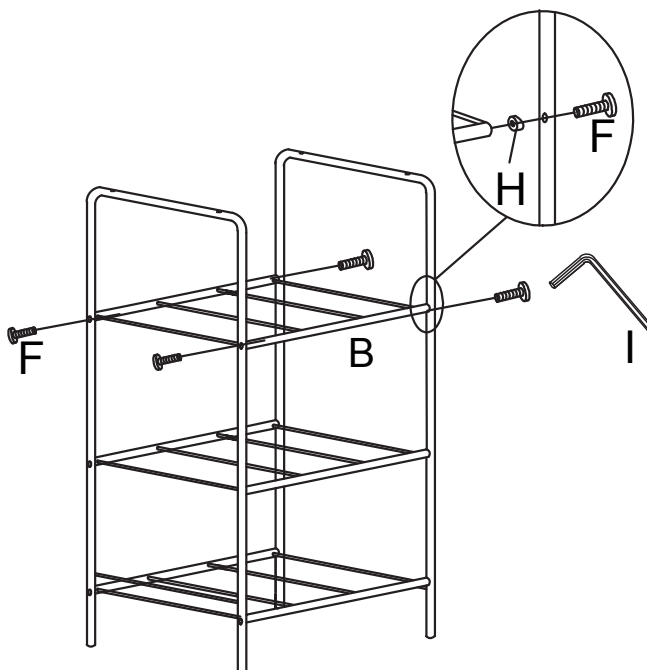

**STEP 4**

ATTACH TOP PANEL (E) TO THE STEP (3) METAL FRAME USING SCREW (G) WITH PHILIPS SCREWDRIVER AS SHOWN, THEN TIGHTEN ALL THE BOLTS AND SCREWS.

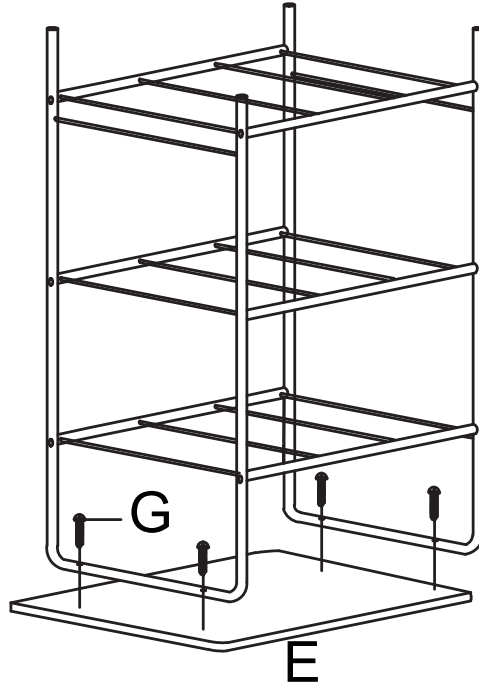

**STEP 5**

ATTACH THE LOCKING CASTER (K) AND CASTER (L) TO THE STEP (4) FRAME WITH ACCESSARY WRENCH (J) AS SHOWN.

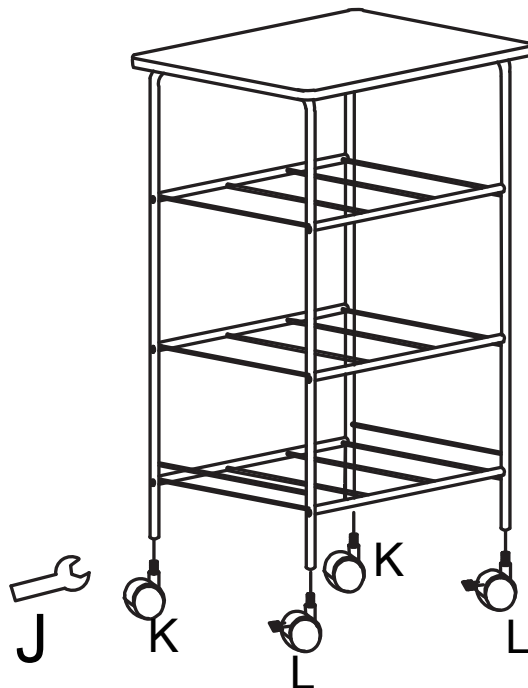

**STEP 6**

UNFOLD THE NON-WOVEN BIN (C) AND PLACE THE BOTTOM PLATE (D) INTO THE BIN (C) AS SHOWN.

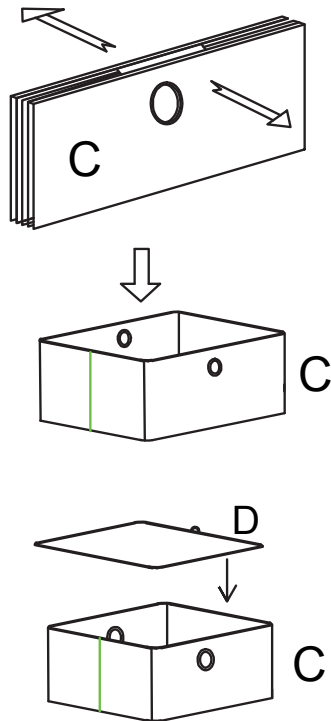

**STEP 7**

PLACE THE NON-WOVEN BIN (C) TO THE SHELF AS SHOWN.

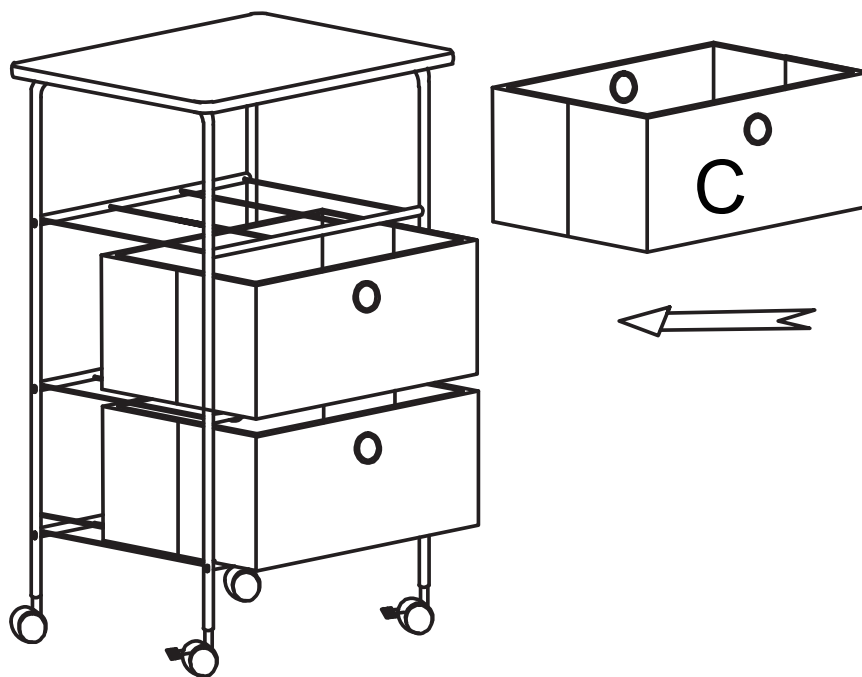

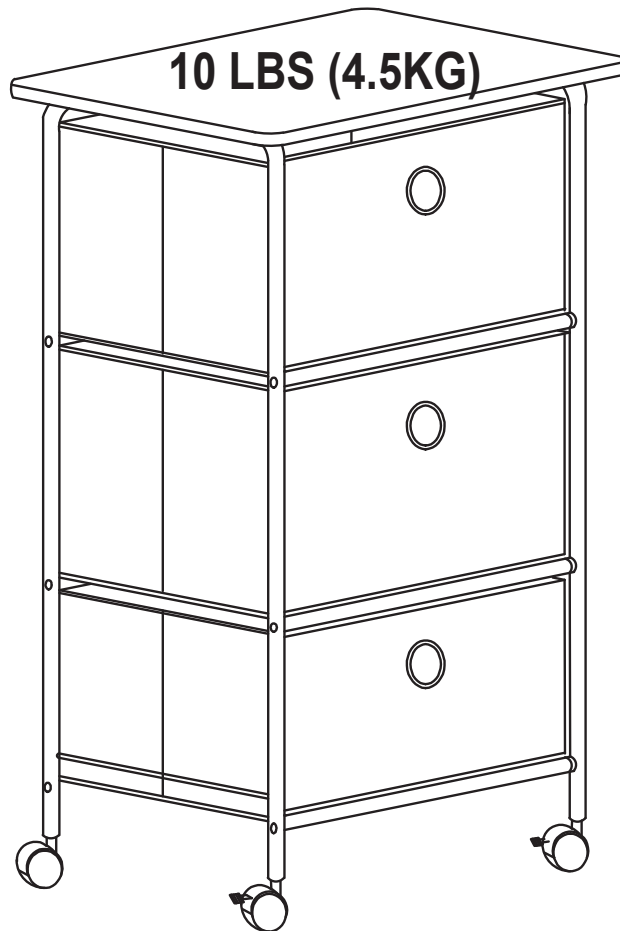

**CAUTION:**  
MAXIMUM LOADING CAPACITY FOR EACH SHELF IS  
10 LBS (4.5 KG)

**⚠ CAUTION: MAXIMUM LOADING CAPACITY IS 10 LBS.**  
**DO NOT SIT, STAND, LEAN, WALK OR JUMP! FAILURE TO COMPLY WITH THIS CAUTION COULD RESULT IN PERSONAL INJURY AND/OR PROPERTY DAMAGE!**

This unit is intended for use only with the products and maximum weights indicated. Use with other products or products heavier than the maximum weights indicated may result in instability causing possible injury. Furniture can tip over or break if improperly moved. Have a friend help to lift and carry the unit to it's new location.

Do you have any questions? Missing small parts or hardware? If you need assistance with the assembly of your **STORAGE SHELF 3 DRAWER** please e-mail our Customer Service Department at: **support@fourstari.com** or **call us at (508) 473-7688, (800) 639-3803** or visit **www.fourstari.com**

Please include the following information when contacting us:

- Where item was purchased
- Item, model, style or SKU number listed on instructions or box
- Part number, description of the part and quantity needed
- Copy of Proof of Purchase from Authorized Reseller Required

This information will help us get the proper part to you faster.