

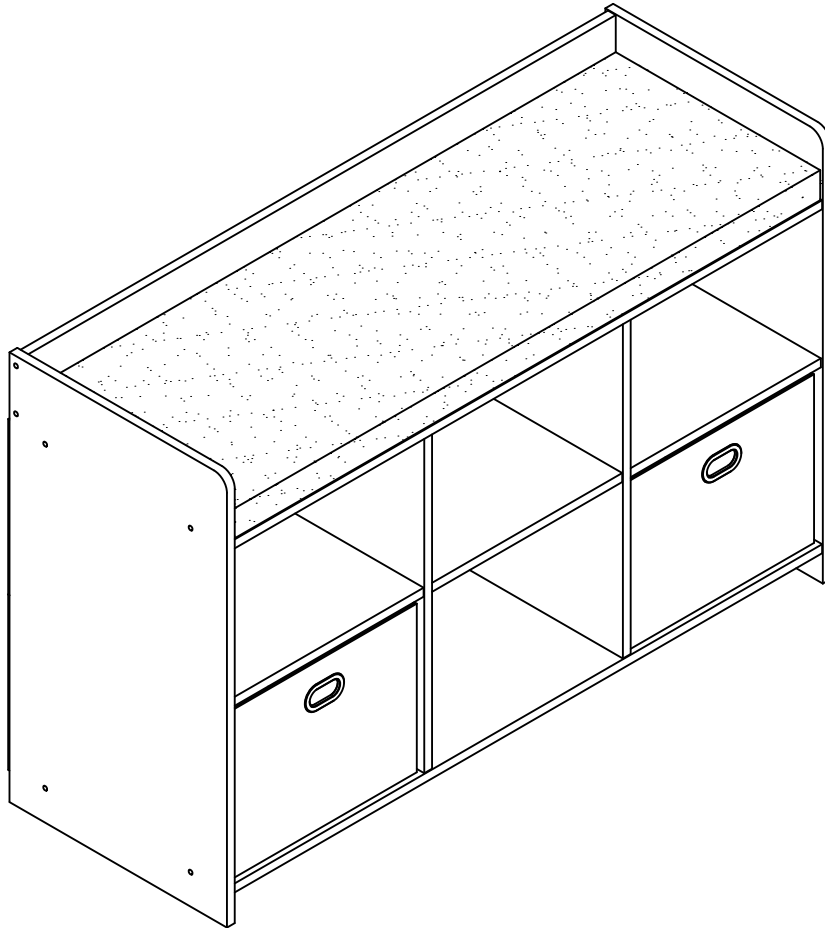









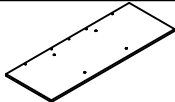
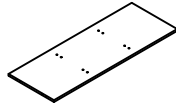
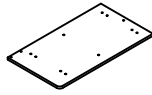
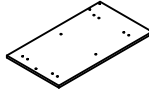
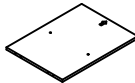
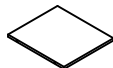
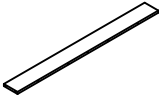

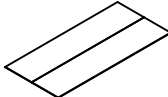
fourstargroup



MODEL: 11224955 / MODELO: 11224955

**STORAGE BENCH WITH 2 BINS
NO PARTS LIST QTY
BANCO DE A ALMACENAMIENTO
CON 2 CAJONES**

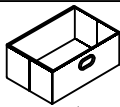
NO/Nº	PARTS LIST/LISTA DE PIEZAS		QTY CANT
A	TOP PANEL / SUPERFICIE DE LA MESA		1PC 1PZ
B	BOTTOM PANEL / PANEL INFERIOR		1PC 1PZ
C	LEFT SIDE PANEL PANEL LATERAL IZQUIERDO		1PC 1PZ
D	RIGHT SIDE PANEL PANEL LATERAL DERECHO		1PC 1PZ
E	CENTER PANEL / PANEL CENTRAL		2PCS 2PZS
F	SHELF PANEL / ESTANTE		3PCS 3PZS
G	TOP BACK PANEL PANEL POSTERIOR SUPERIOR		1PC 1PZ
H	BOTTOM BAR / BARRA INFERIOR		1PC 1PZ
I	BACK PANEL / PANEL POSTERIOR		1PC 1PZ

NO/Nº	HARDWARE LIST		QTY CANT
1	SMALL PLASTIC DOWEL M6x20mm M6X20MM CLAVIJA DE PLÁSTICO PEQUEÑA		27PCS 27PZS
2	LARGE PLASTIC DOWEL M6x40mm M6X40MM CLAVIJA DE PLÁSTICO GRANDE		4PCS 4PZS
3	C/B SCREW M4x38mm C/B TORNILLO M4X38MM		23PCS 23PZS
4	POWER PIN / CLAVO		18PCS 18PZS
5	NAIL LEG / PATA CON CLAVO		6PCS 6PZS
6	NON-WOOVEN BIN / CAJON DE TELA		2PCS 2PZS
7	CUSHION / ALMOHADA		1PC 1PZ

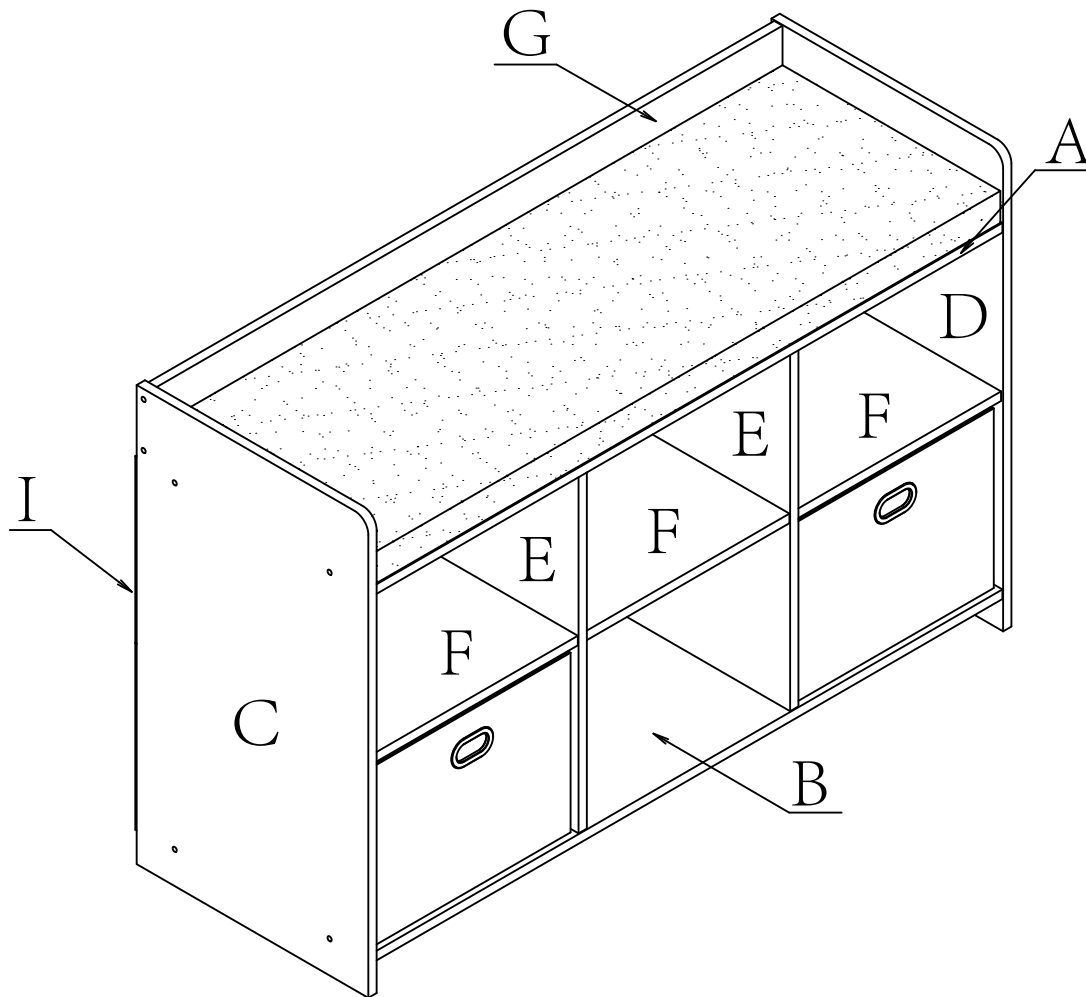

BEFORE YOU BEGIN, PLEASE READ ASSEMBLY INSTRUCTIONS CAREFULLY.
FOLLOW THEM STEP BY STEP.

ANTES DE EMPEZAR, LEA CUIDADOSAMENTE LAS INSTRUCCIONES DE MONTAJE .
SIGALAS PASO A PASO.

CAUTION:

1. ADULT SUPERVISION IS REQUIRED DUE TO SMALL PARTS.
2. CARE SHOULD BE TAKEN WHEN UNPACKING PARTS AND ASSEMBLING PRODUCT.
3. MAKE SURE ALL PARTS ARE INCLUDED BEFORE ASSEMBLING.
4. ASSEMBLE ON A SOFT SURFACE TO PREVENT DAMAGE TO THE PRODUCT'S FINISH.

PRECAUCIÓN :

- 1 . LA SUPERVISIÓN DE UN ADULTO ES REQUERIDA POR HABER PIEZAS PEQUEÑAS.
- 2 . TENGA CUIDADO CUANDO DESARME Y ARME EL PRODUCTO.
- 3 . ASEGÚRATE DE QUE TODAS LAS PIEZAS ESTÉN INCLUIDAS ANTES DE ARMAR.
- 4 . MONTAR EN UNA SUPERFICIE SUAVE PARA EVITAR DAÑOS AL ACABADO DEL PRODUCTO.

ASSEMBLY TOOLS REQUIRED

HERRAMIENTAS DE MONTAJE NECESARIAS

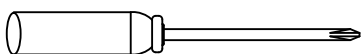

SCREWDRIVER / DESTORNILLADOR

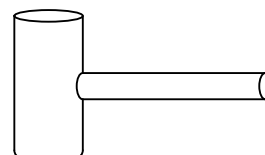

RUBBER Mallet / MAZO DE GOMA

ASSEMBLY INSTRUCTION

INSTRUCCIONES DE MONTAJE

STEP 1

INSERT SMALL DOWELS (1) INTO PANELS (A) (B) (E) & (G) AND BOTTOM BAR (H) AS SHOWN.

PASO 1

INSERTE CLAVIJAS PEQUEÑAS (1) EN LOS PANELES (A) (B) (E) Y (G) Y LA BARRA INFERIOR (H) COMO SE MUESTRA .

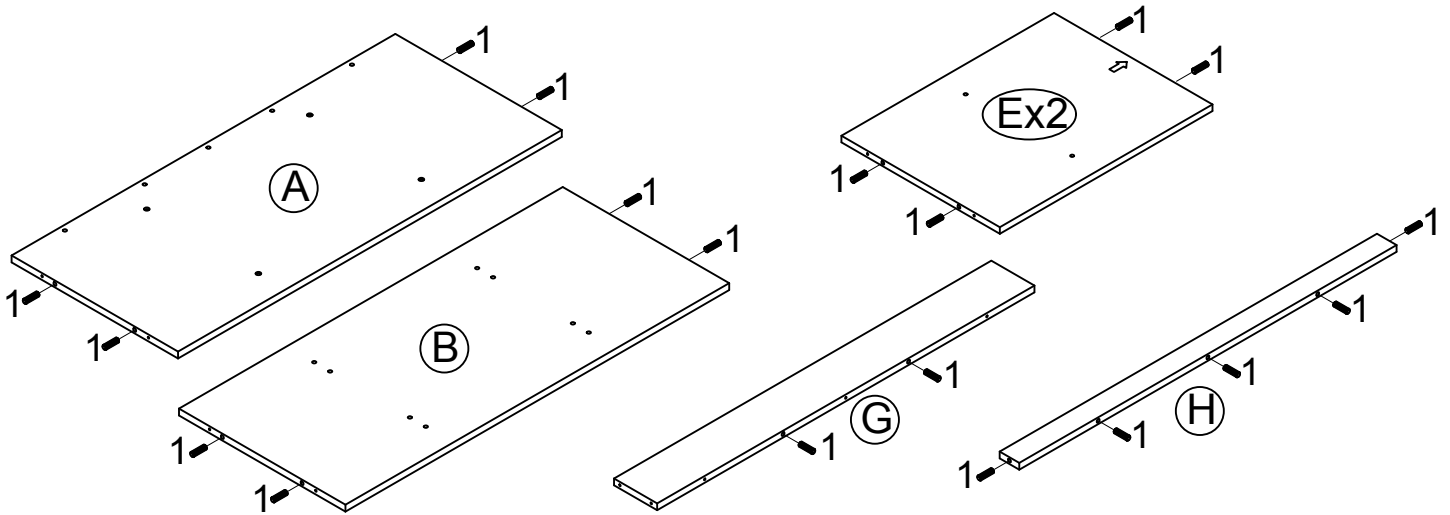

STEP 2

INSERT NAIL LEGS (5) INTO SIDE PANELS (C) & (D) AND BOTTOM BAR (H) WITH RUBBER Mallet AS SHOWN.

PASO 2

MARTILLE LAS PATAS CON CLAVO (5) EN LOS PANELES LATERALES (C) Y (D) Y LA BARRA INFERIOR (H) CON UN MAZO DE GOMA COMO SE MUESTRA .

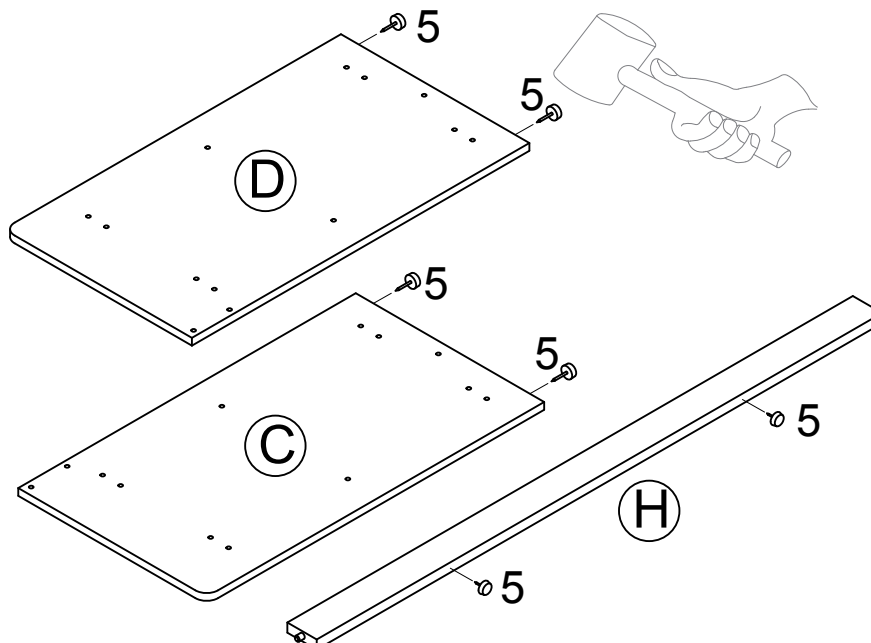

STEP 3

ATTACH TOP BACK PANEL (G) TO TOP PANEL (A) WITH SCREWS (3) AS SHOWN.

PASO 3

FIJE EL PANEL POSTERIOR SUPERIOR (G) AL PANEL SUPERIOR (A) CON LOS TORNILLOS (3) COMO SE MUESTRA.

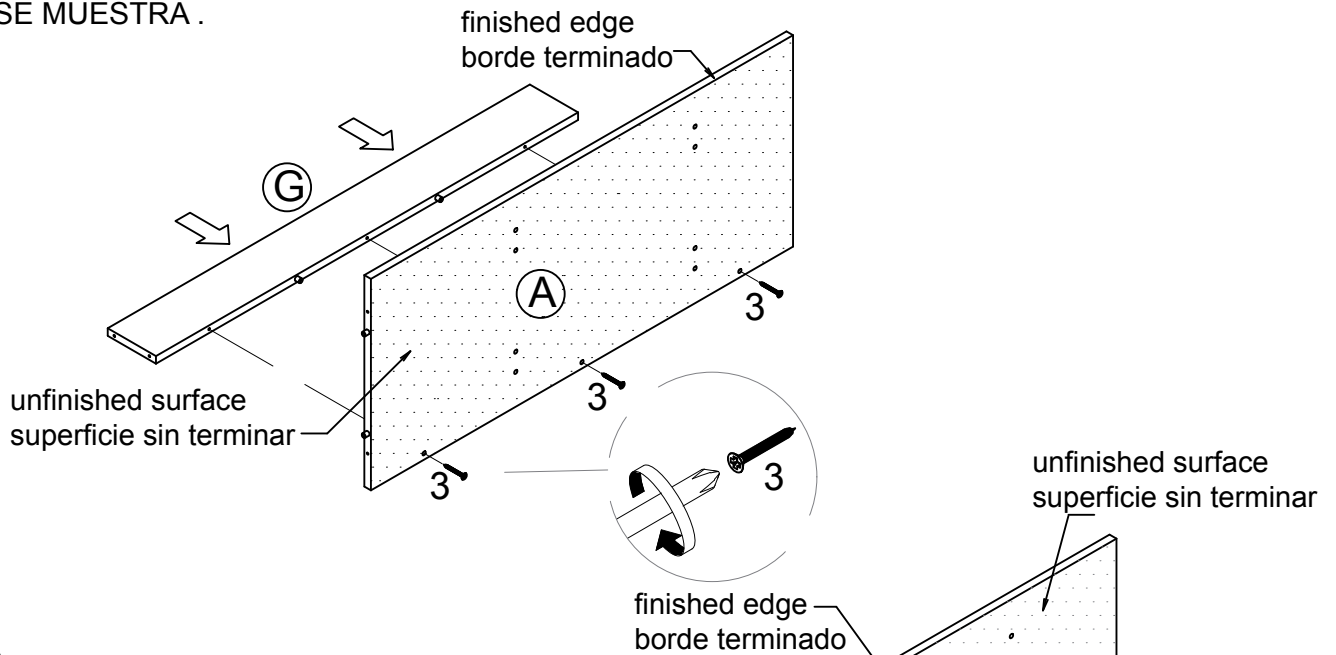

STEP 4

ATTACH BOTTOM BAR (H) TO BOTTOM PANEL (B).

PASO 4

FIJE BARRA INFERIOR (H) AL PANEL INFERIOR (B).

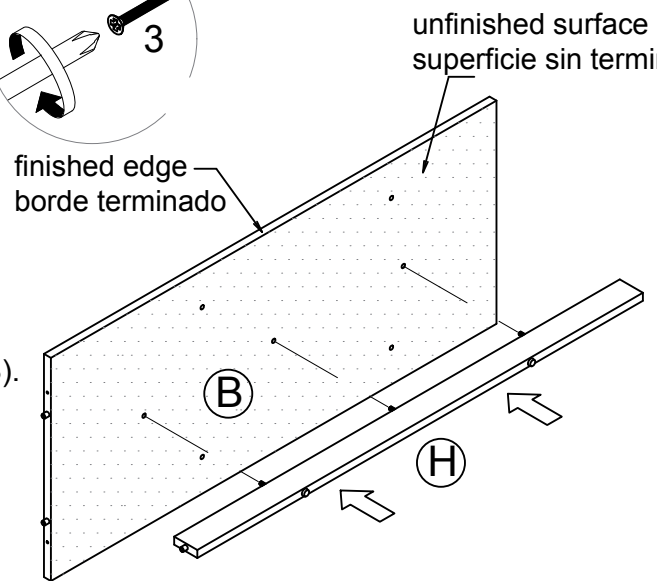

STEP 5

ATTACH SHELF PANELS (F) TO CENTER PANELS (E). WITH SMALL AND LARGE DOWELS (1) & (2) AS SHOWN.

PASO 5

FIJE LOS ESTANTES (F) A LOS PANELES CENTRALES (E) CON CLAVIJAS PEQUEÑAS Y GRANDES (1) Y (2) COMO SE MUESTRA.

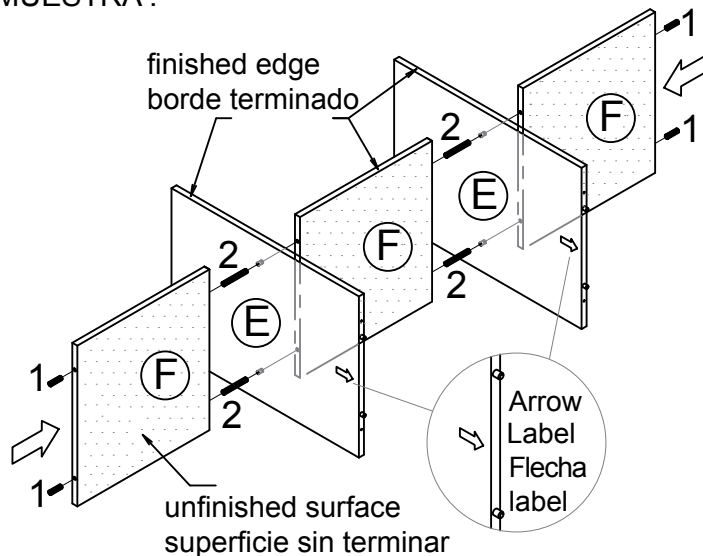

STEP 6

ATTACH TOP PANEL (A) AND BACK PANEL (B) TO ASSEMBLED UNIT FROM STEP 5 WITH SCREWS (3) AS SHOWN.

PASO 6

FIJE PANEL SUPERIOR (A) Y EL PANEL TRASERO (B) A LA UNIDAD MONTADA EN PASO 5 CON LOS TORNILLOS (3) COMO SE MUESTRA .

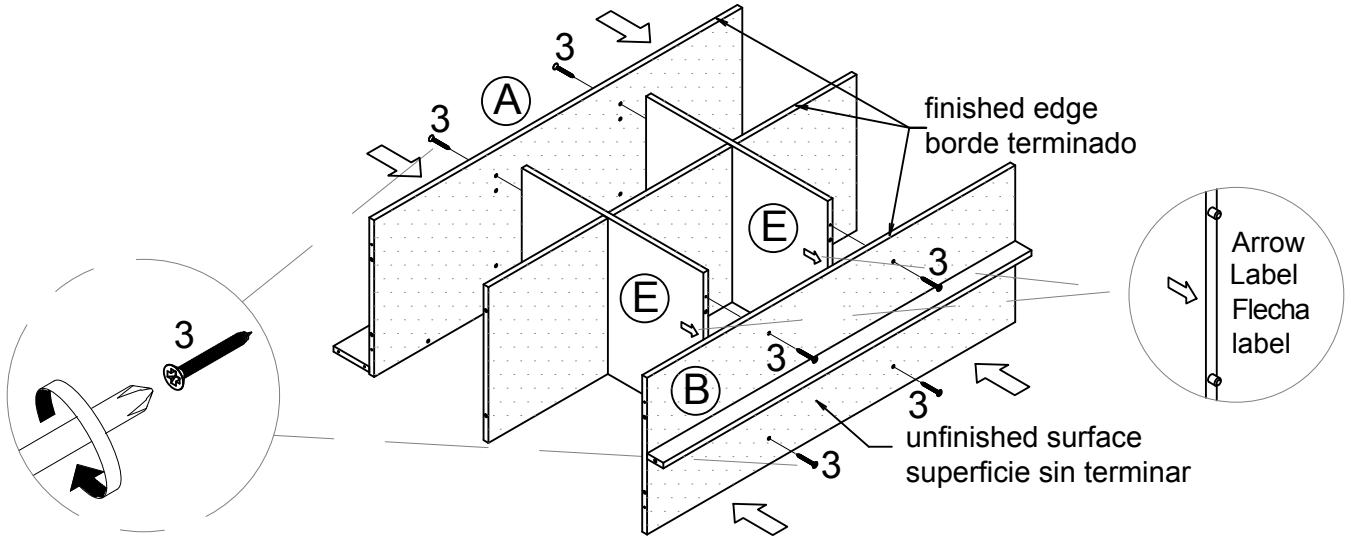

STEP 7

ATTACH SIDE PANELS (C) & (D) TO ASSEMBLED UNIT FROM STEP 6 WITH SCREWS (3) AS SHOWN.

PASO 7

FIJE LOS PANELES LATERALES (C) Y (D) A LA UNIDAD MONTADA EN PASO 6 CON LOS TORNILLOS (3) COMO SE MUESTRA .

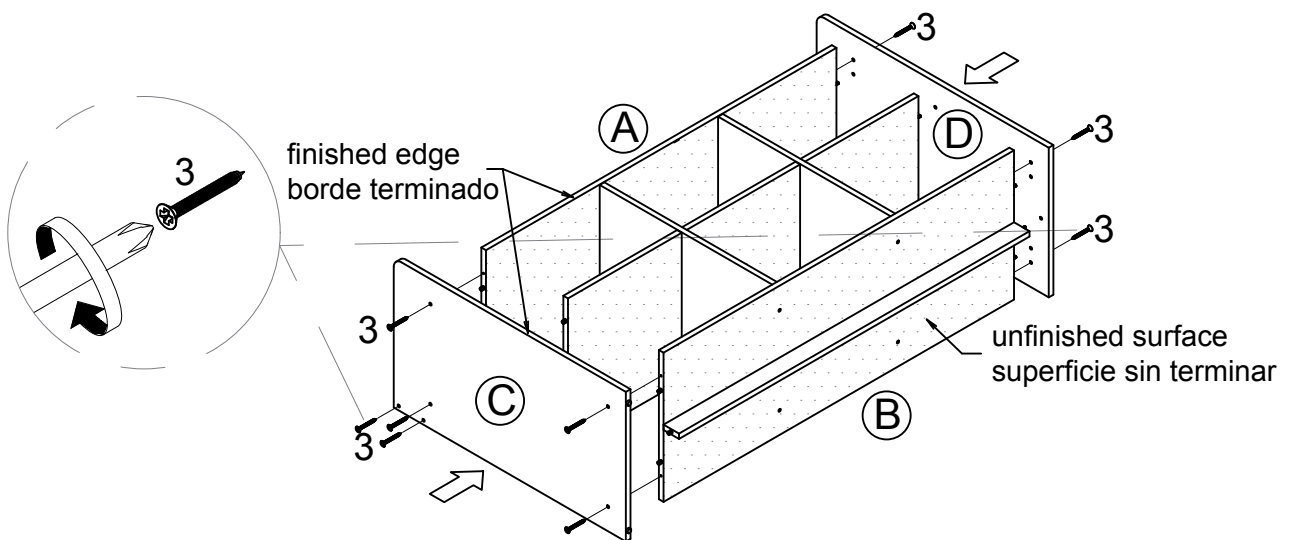

STEP 8

ATTACH BACK PANEL (J) TO THE BACK OF STORAGE BENCH WITH POWER PINS (4).

PASO 8

ADJUNTE EL PANEL TRASERO (J) AL FINAL DE BANCO DE ALMACENAMIENTO CON CLAVOS (4).

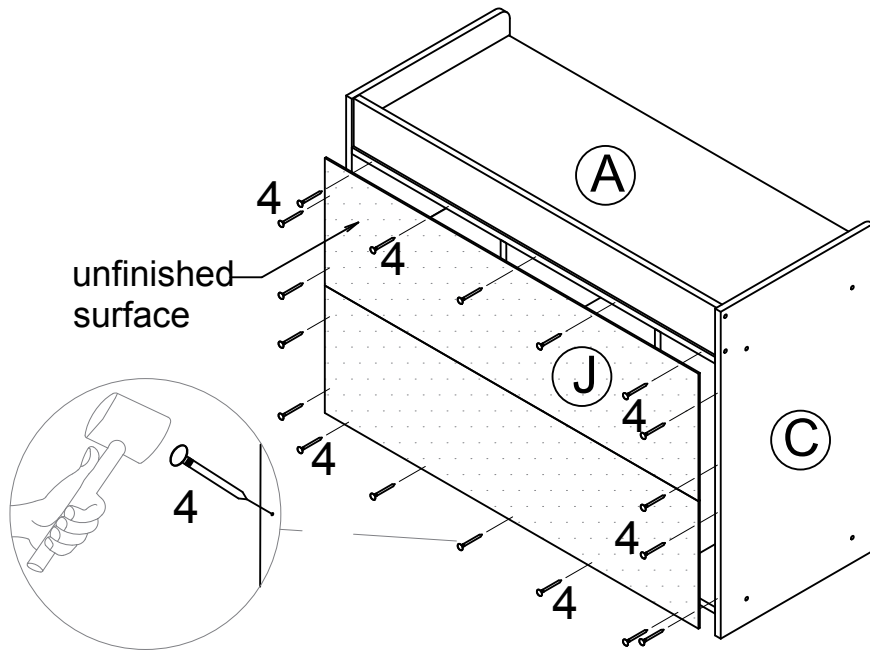

STEP 9

UNFOLD THE BINS (6) AND SLIDE INTO TWO OF THE STORAGE BENCH'S BOTTOM CUBBIES. PLACE CUSHION (7) ON TOP PANEL (A).

PASO 9

DESPLIEGUE LOS CONTENEDORES (6) Y EMPUJELOS AL FONDO DEL BANCO DE ALMACENAMIENTO. COLOQUE LA ALMOHADA (7) EN PANEL SUPERIOR (A).

