

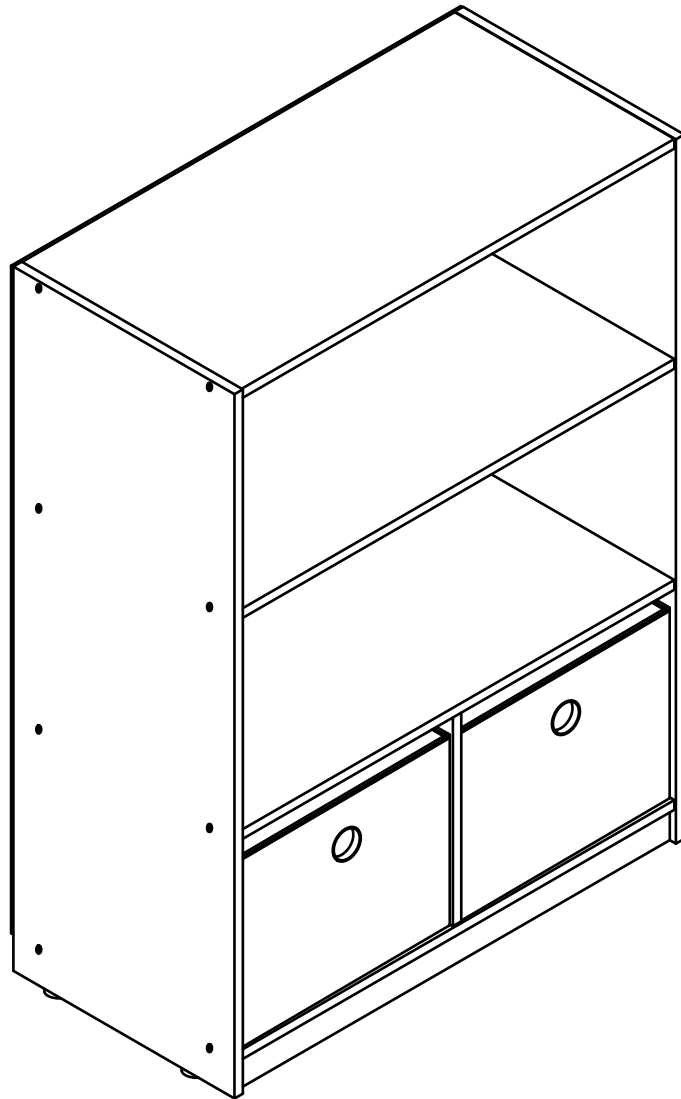

fourstargroup











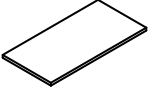
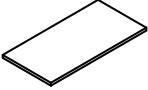
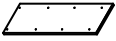
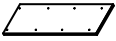
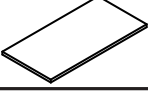

MODEL: 11224630R / MODELO: 11224630R

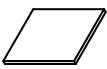
STORAGE SHELF WITH 2 BINS

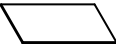
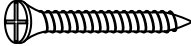
**ESTANTE DE ALMACENAMIENTO
CON 2 CONTENEDORES**

PARTS AND HARDWARE

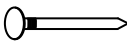
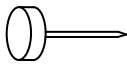
LISTA DE PARTES Y HARDWARE

NO			QTY CNT
A	TOP PANEL PANEL SUPERIOR		1 PC 1 PZ
B	LEFT SIDE PANEL PANEL LATERAL IZQUIERDO		1 PC 1 PZ
C	RIGHT SIDE PANEL PANEL LATERAL DERECHO		1 PC 1 PZ
D	1ST SHELF PANEL 1 ESTANTE		1 PC 1 PZ
E	2ND SHELF PANEL 2 ESTANTE		1 PC 1 PZ
F	BOTTOM PANEL PANEL INFERIOR		1 PC 1 PZ
G	CENTER PANEL PANEL CENTRAL		1 PC 1 PZ
H	BOTTOM CROSSBAR TRAVESAÑO INFERIOR		1 PC 1 PZ
I	BACK PANEL PANEL POSTERIOR		2 PCS 2 PZS
1	LONG SCREW TORNILLO LARGO		16 PCS 16 PZS
2	SHORT SCREW TORNILLO CORTO		4 PCS 4 PZS
3	DOWEL CLAVIJA DE MADERA		4 PCS 4 PZS
4	L-BRACKET SOPORTE -L-		2 PCS 2 PZS
5	POWER PIN CLAVO		16 PCS 16 PZS
6	NAIL LEG PATA CON CLAVO		4 PCS 4 PZS
7	NON-WOOVEN BIN CAJON DE TELA		2 PCS 2 PZS
8	SCREW CAP COVER TAPA CUBRE TORNILLO		2 PCS 2 PZS

ASSEMBLY INSTRUCTIONS

INSTRUCCIONES DE ENSAMBLAJE

CAUTION:

1. ADULT SUPERVISION IS REQUIRED DUE TO SMALL PARTS. CARE SHOULD BE TAKEN IN THE UNPACKING AND ASSEMBLING OF THIS PRODUCT.
 2. ASSEMBLE ON SOFT SURFACE TO PREVENT DAMAGE TO THE PRODUCT FINISH.
 3. MAKE SURE ALL PARTS ARE INCLUDED BEFORE ASSEMBLING.
- BEFORE YOU BEGIN, PLEASE READ ASSEMBLY INSTRUCTIONS CAREFULLY. FOLLOW STEP BY STEP.

PRECAUCIÓN:

1. SE REQUIERE LA SUPERVISION DE UN ADULTO DEBIDO A LA EXISTENCIA DE PIEZAS PEQUEÑAS. DEBE TENER CUIDADO AL DESEMPACAR Y EN EL MONTAJE DE ESTE PRODUCTO.
2. ENSAMBLELO SOBRE SUPERFICIES SUAVES PARA EVITAR DAÑAR EL ACABADO DEL PRODUCTO.
3. ASEGURESE DE QUE ESTÉN TODAS LAS PIEZAS ANTES DEL MONTAJE. ANTES DE COMENZAR, POR FAVOR LEA CUIDADOSAMENTE LAS INSTRUCCIONES DE MONTAJE. SEGUIRLAS PASO A PASO.

ASSEMBLY TOOLS REQUIRED

SCREWDRIVER

HAMMER

HERRAMINETAS DE MONTAJE REQUERIDOS

DESTORNILLADOR

MARTILLO

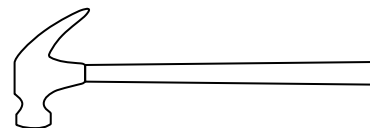
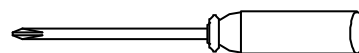

STEP 1

INSERT DOWEL (3) TO PANEL (G).

PASO 1

INSERTE LA CLAVIJA DE MADERA (3) AL PANEL (G).

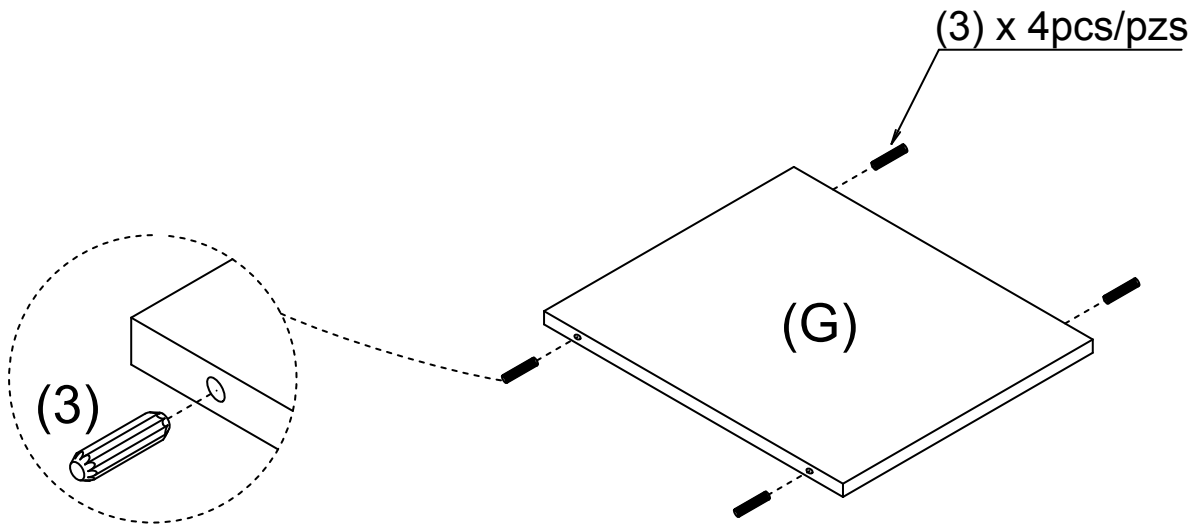

STEP 2

INSTALL L-BRACKET (4) TO PANEL (H) WITH SCREW (2).

*** FOLLOW THE MARKING ON THE PANEL.**

PASO 2

INSTALAR SOPORTE -L-(4) AL PANEL (H) CON EL TORNILLO (2).

*** SEGUIR LA MARCA EN EL PANEL.**

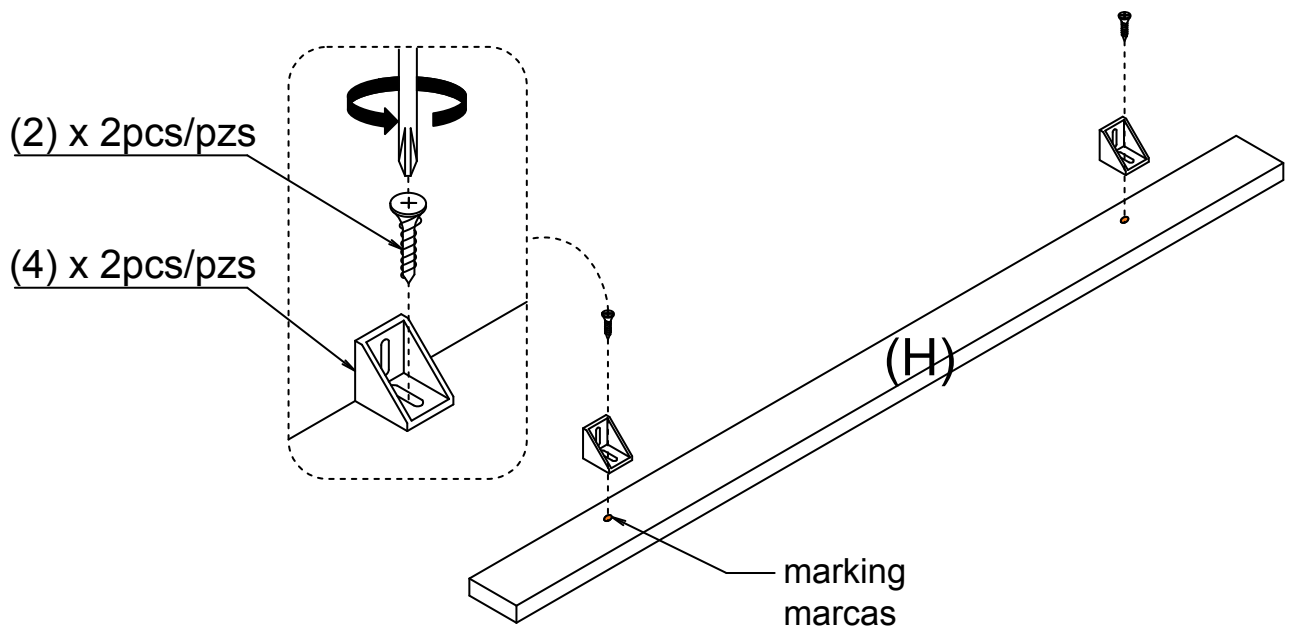

STEP 3

ATTACH PANEL (H) TO PANEL (F) WITH SCREW (2).

*** FOLLOW THE MARKING ON THE PANEL.**

PASO 3

FIJE EL PANEL (H) AL PANEL (F) CON EL TORNILLO (2).

*** SEGUIR LA MARCA EN EL PANEL.**

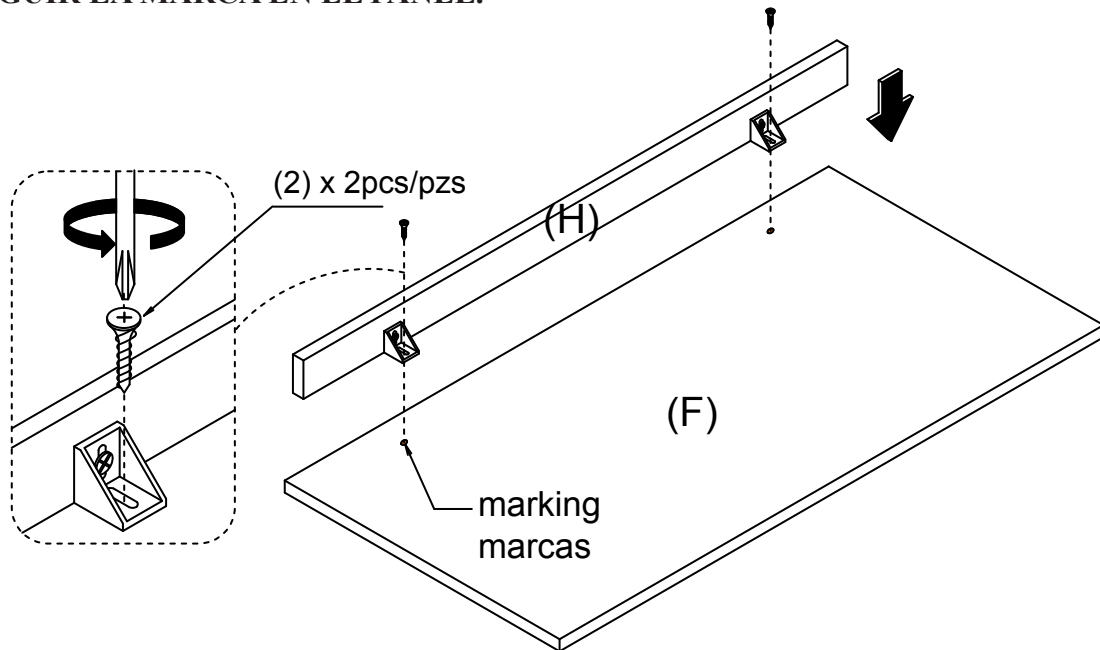

STEP 4

ATTACH ASSEMBLED PANEL (F) TO PANEL (B) & (C) WITH SCREW (1).

PASO 4

FIJE EL PANEL (F) AL PANEL (B) Y (C) CON EL TORNILLO (1).

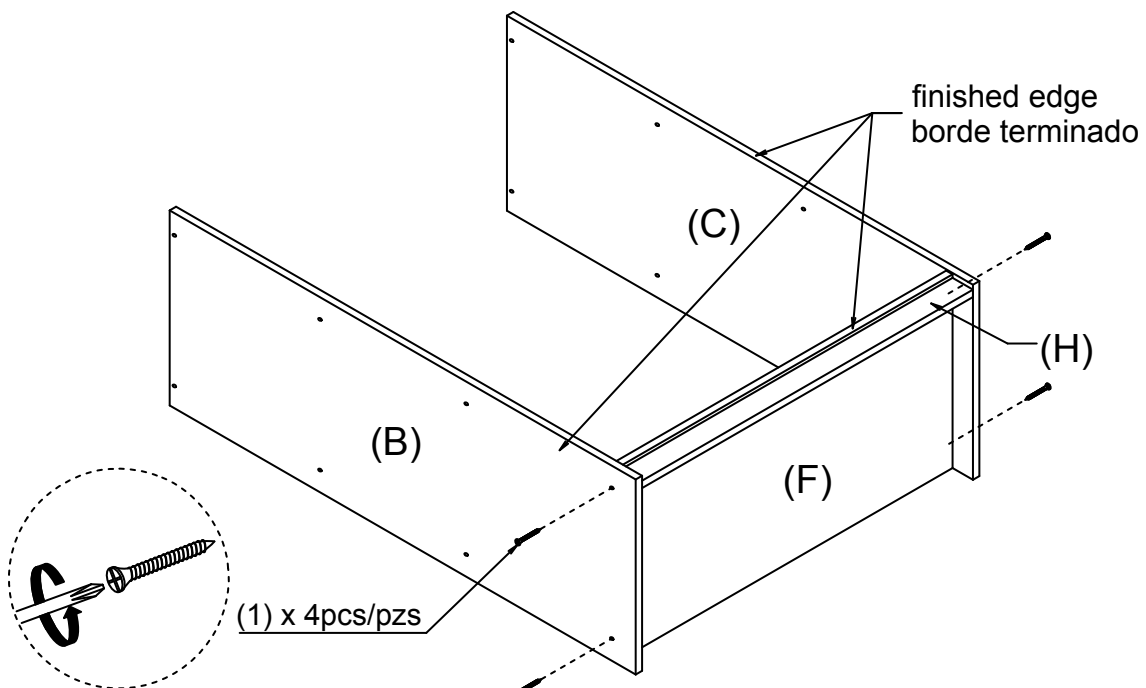

STEP 5

ATTACH PANEL (G) TO PANEL (F).

PASO 5

FIJE EL PANEL (G) AL PANEL (F).

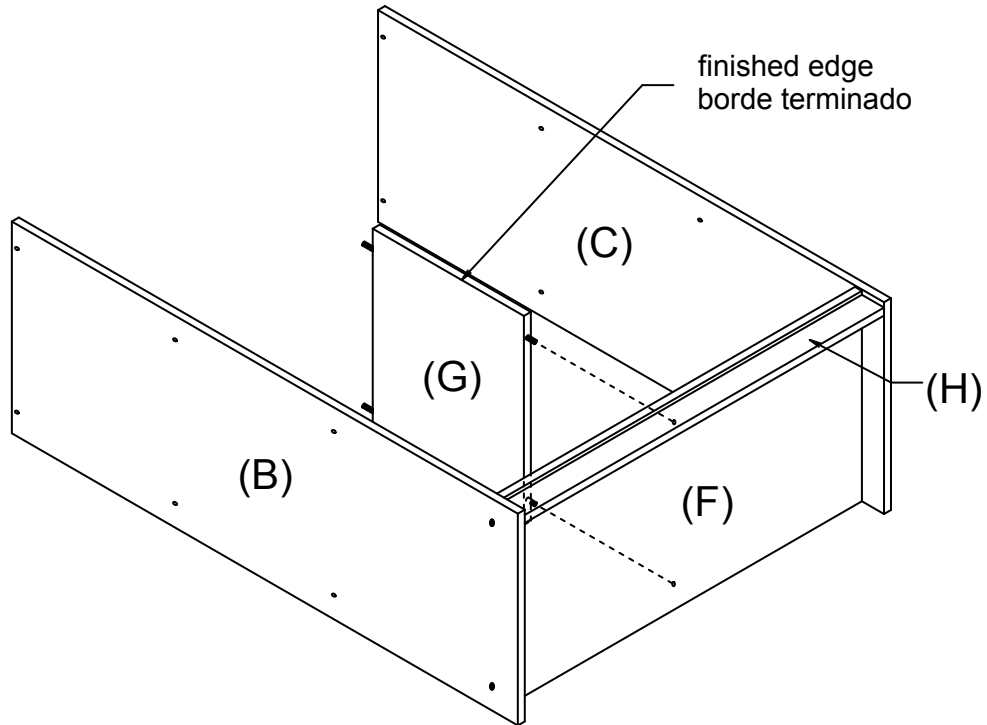

STEP 6

ATTACH PANEL (A), (D) & (E) TO PANEL (B) & (C) WITH SCREW (1).

PASO 6

FIJE EL PANEL (A), (D) Y (E) AL PANEL (B) Y (C) CON EL TORNILLO (1).

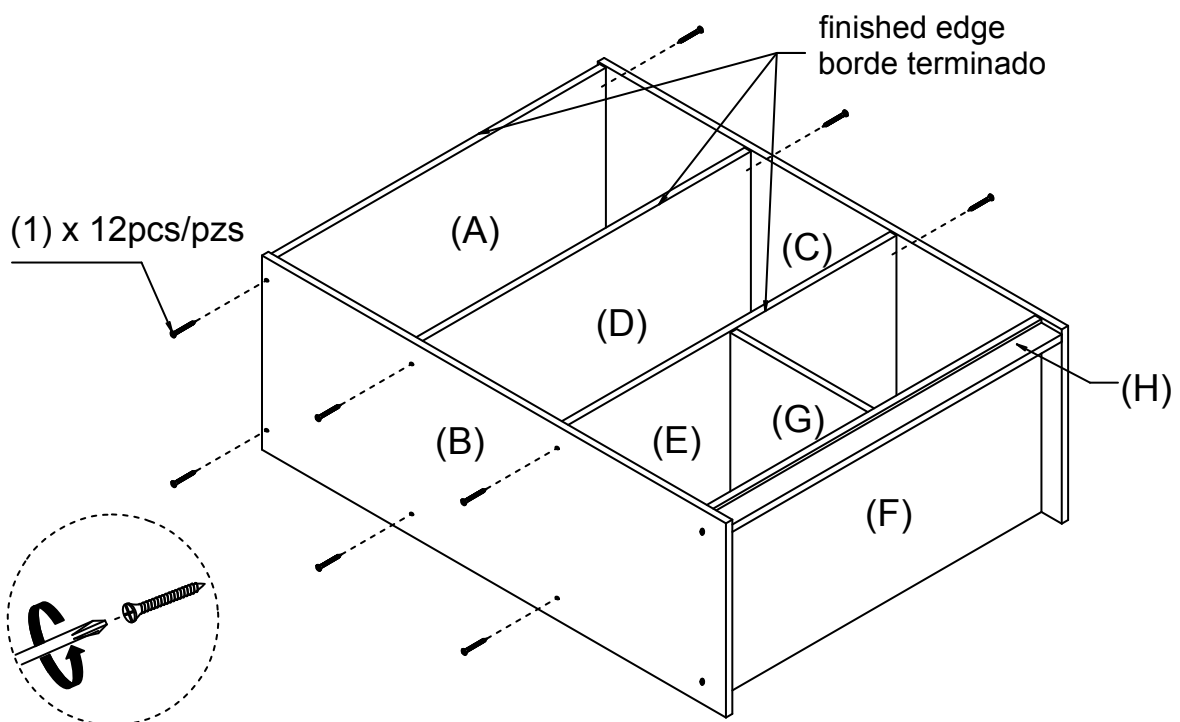

STEP 7

INSTALL NAIL LEG (6) TO THE BOTTOM SIDE OF PANEL (B) & (C) WITH HAMMER.

PASO 7

INSTALAR PAA CON CLAVO (6) A LA PARTE INFERIOR DEL PANEL (B) Y (C) CON UN MARTILLO.

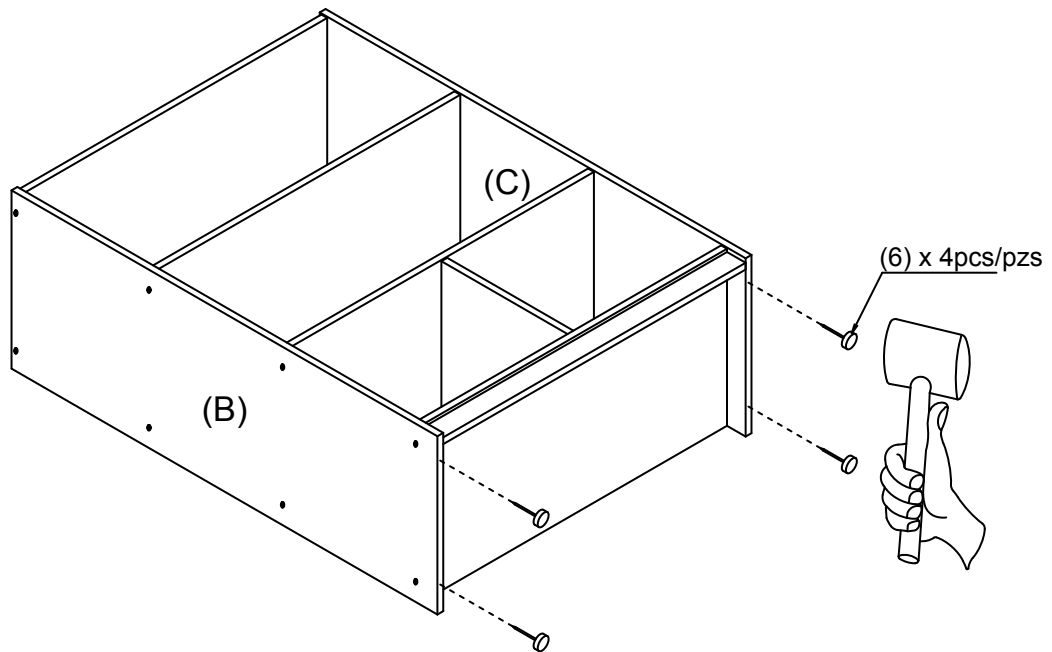

STEP 8

ATTACH BACK PANEL (I) TO THE BACK OF STORAGE WITH POWER PIN (5).

PASO 8

FIJE EL PANEL POSTERIOR (I) A LA PARTE TRASERA DEL ALMACENAMIENTO CON LOS CLAVOS (5).

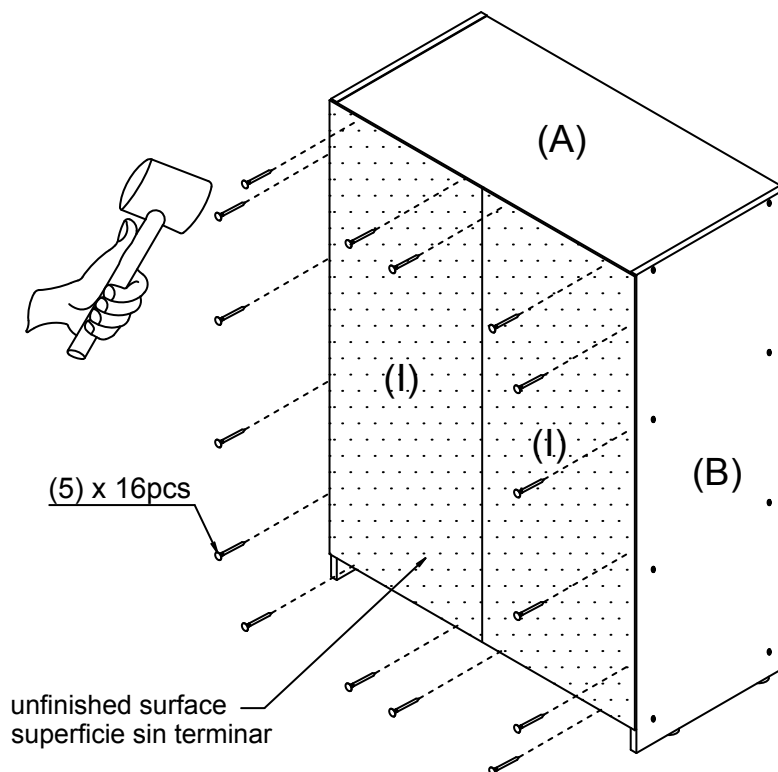

STEP 9

9.1 UNFOLD THE BIN (7) AND SLIDE INTO THE STORAGE.

9.2 COVER THE SCREW POSITION WITH SCREW CAP (8).

PASO 9

9.1 DESDOBLE EN CAJON DE TELA (7) Y COLOQUELO EN EL ALMACENAMIENTO.

9.2 CUBRIR LOS TORNILLOS CON LA TAPA CUBRE TORNILLO (8).

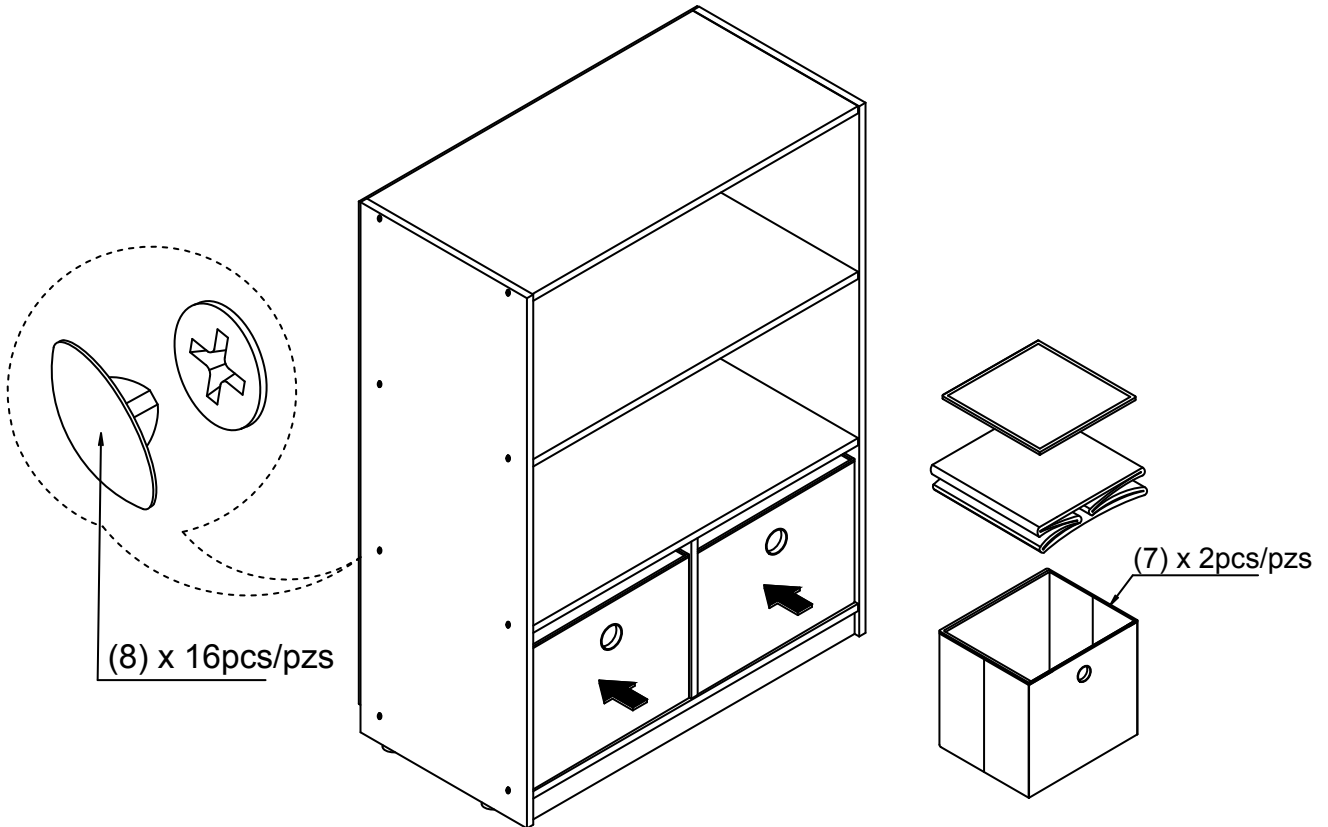

This unit is intended for use only with the products and maximum weights indicated. Use with other products or products heavier than the maximum weights indicated may result in instability causing possible injury. Furniture can tip over or break if improperly moved. Have a friend help to lift and carry the unit to it's new location.

Esta unidad está destinada sólo para su uso con los productos y pesos máximos indicados. Si usted utilice esta mesa con otros productos o de los productos más pesados que el peso máximo indicado, puede causar inestabilidad y puede dar lugar a posibles lesiones. La mesa puede volcarse o romperse si es trasladada indebidamente. Se sugiere tener un amigo para que le ayude a levantar y transportar la mesa a su nueva ubicación.

Do you have any questions? Missing small parts or hardware? If you need assistance with the assembly of your STORAGE SHELF WITH 2 BINS please e-mail our Customer Service Department at:

support@fourstari.com or call us at **(800) 639-3803** or **(508) 473-7688** if calling locally from Massachusetts area

Please include the following information in your email:

• Where item was purchased • Item, model, style or SKU number listed on instructions or box • Part number, description of the part and quantity needed

This information will help us get the proper part to you faster

¿Tiene alguna pregunta? ¿Faltan piezas o accesorios pequeños? Si necesita ayuda para ensamblar su ESTANTE DE ALMACENAMIENTO CON 2 CONTENEDORES envíenos un correo electrónico a nuestro Departamento de atención al cliente:

ayuda@fourstari.com o llámenos al **(800) 639-3803** o **(508) 473-7688** si llama desde la zona de Massachusetts Incluya la siguiente información en el correo electrónico:

• Dónde compró el producto • El número de artículo, SKU, estilo, modelo o producto que aparece en las instrucciones o la caja • El número y descripción de la pieza y la cantidad que necesita

Esta información nos ayudará a enviarle la pieza correcta con mayor rapidez