

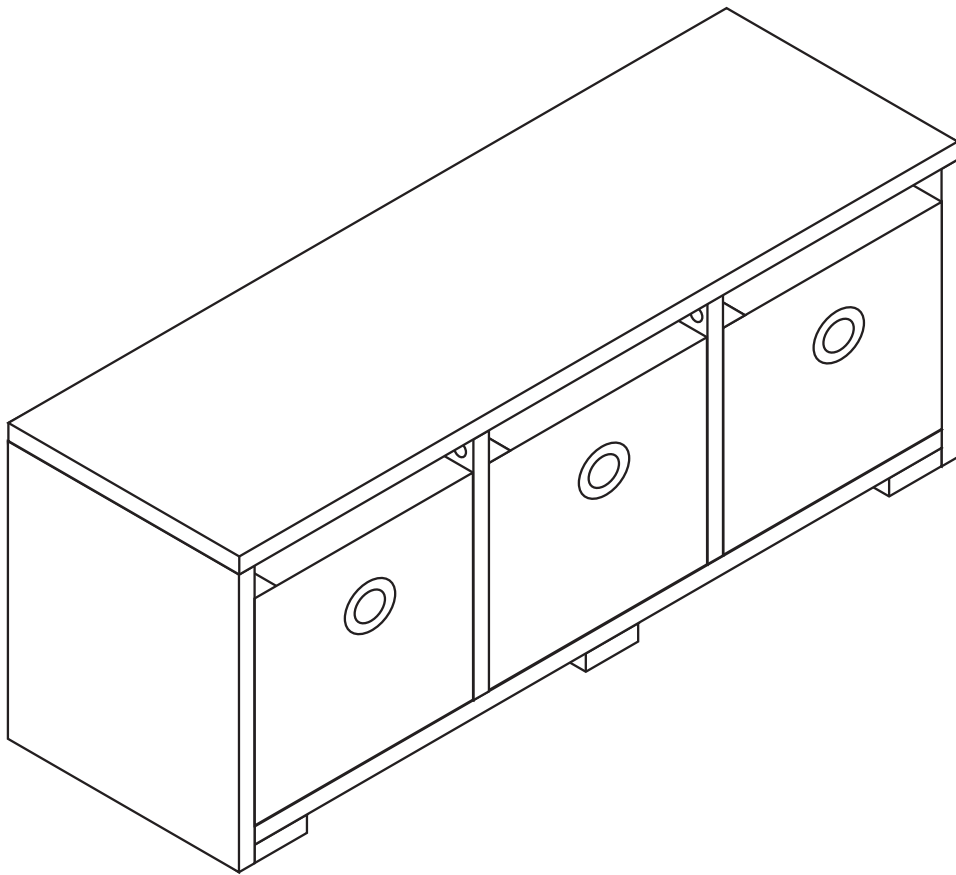

fourstargroup









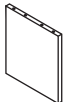
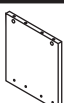

MODEL: 11224442 / MODELO: 11224442

**WOODEN STORAGE BENCH
WITH 3 BINS**

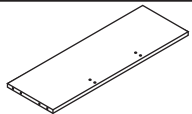
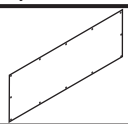
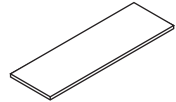
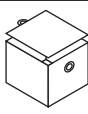
**BANCO CON ALMACENAMIENTO
DE 3 CAJONES**

PARTS LIST

PARTES Y ACCESORIOS

NO	PARTS LIST / LISTA DE PARTES	QTY CNT
A	LEFT SIDE PANEL PANEL LATERAL IZQUIERDO 	1 PC 1 PZ
B	RIGHT SIDE PANEL PANEL LATERAL DERECHO 	1 PC 1 PZ
C	BOTTOM BAR BARRA INFERIOR 	3 PCS 3 PZS
D	MIDDLE BAR BARRA MEDIA 	2 PCS 2 PZS
E	BOTTOM PANEL PANEL INFERIOR 	1 PC 1 PZ
F	BACK PANEL PANEL TRASERO 	1 PC 1 PZ
G	TOP PANEL PANEL SUPERIOR 	1 PC 1 PZ
H	BIN CAJON 	3 PCS 3 PZS
a	BOLT PERNO 	12 PCS 12 PZS
b	CAM LOCK LEVA CON TRABA 	12 PCS 12 PZS
c	WOODEN DOWEL CLAVIJA DE MADERA 	12 PCS 12 PZS
d	LARGE SCREW TORNILLO LARGO 	6 PCS 6 PZS
e	SMALL SCREW TORNILLO CORTO 	12 PCS 12 PZS

ASSEMBLY INSTRUCTIONS

INSTRUCCIONES DE ASAMBLEA

BEFORE BEGINNING, PLEASE REVIEW ASSEMBLY INSTRUCTIONS CAREFULLY. FOLLOW THEM STEP BY STEP.

ANTES DE INICIAR, LEA DETENIDAMENTE LAS INSTRUCCIONES DE ASAMBLEA Y SIGALAS PASO A PASO.

STEP 1-1 / PASO 1-1

FIX BOLTS (a) AND WOODEN DOWELS (c) INTO LEFT SIDE PANEL (A) AND RIGHT SIDE PANEL (B), AND THEN ATTACH LEFT SIDE PANEL (A) AND RIGHT SIDE PANEL (B) TO BOTTOM PANEL (E) USING CAM LOCKS (b) AS SHOWN.

COLOQUE LOS PERNOS (a) Y LAS CLAVIJAS DE MADERA (c) AL PANEL LATERAL IZQUIERDO (A) Y AL PANEL LATERAL DERECHO (B), LUEGO ADJUNTE EL PANEL LATERAL IZQUIERDO (A) AL PANEL LATERAL DERECHO (B) AL PANEL INFERIOR (E) USANDO LAS LEVAS CON TRABAS (b) COMO SE MUESTRA.

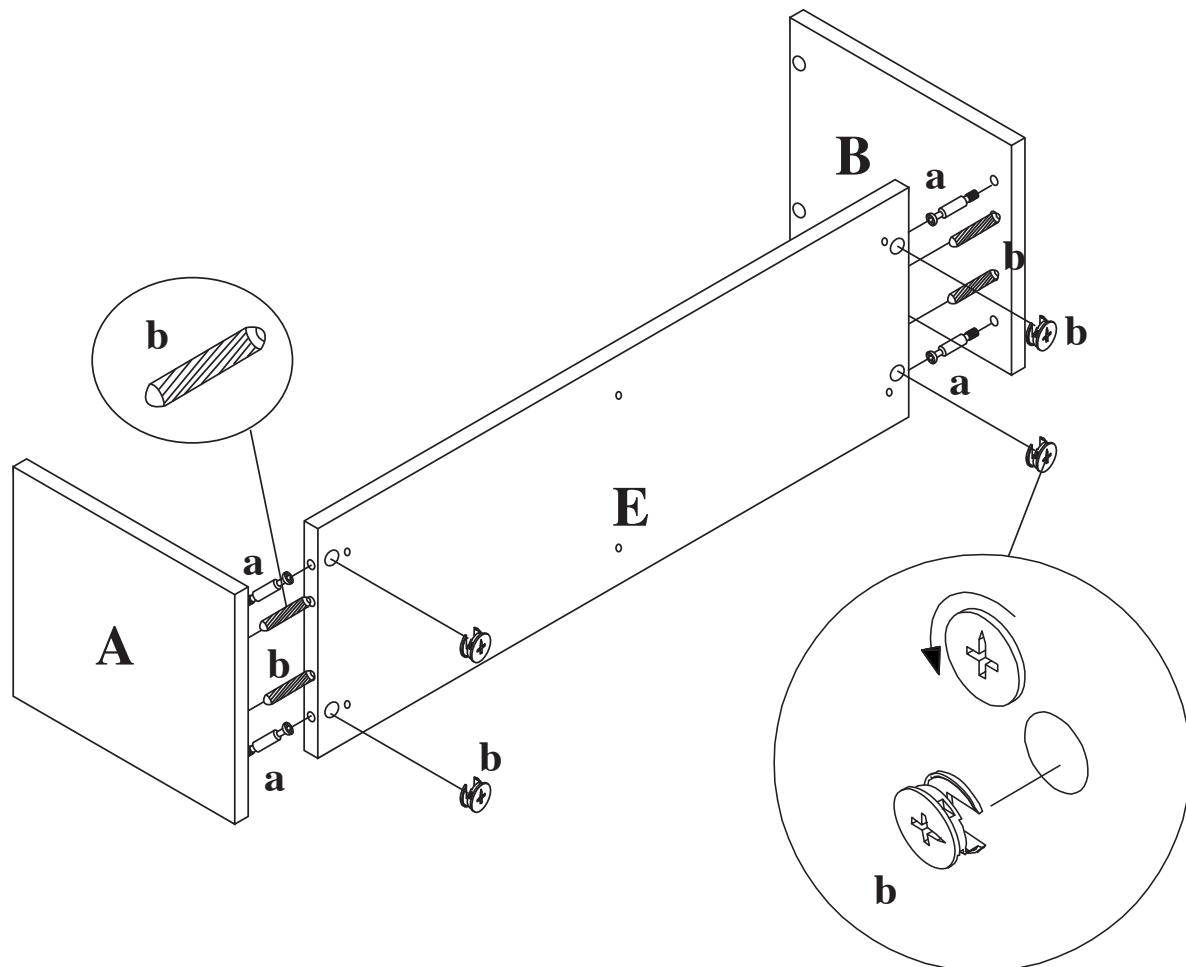

STEP 1-2 / PASO 1-2

ATTACH BOTTOM BARS(C) TO BOTTOM PANEL (E) USING LARGE SCREWS (d) AS SHOWN.

ADJUNTE LAS BARRAS INFERIORES (C) AL PANEL INFERIOR (E) USANDO LAOS TORNILLOS LARGOS (d) COMO SE MUESTRA.

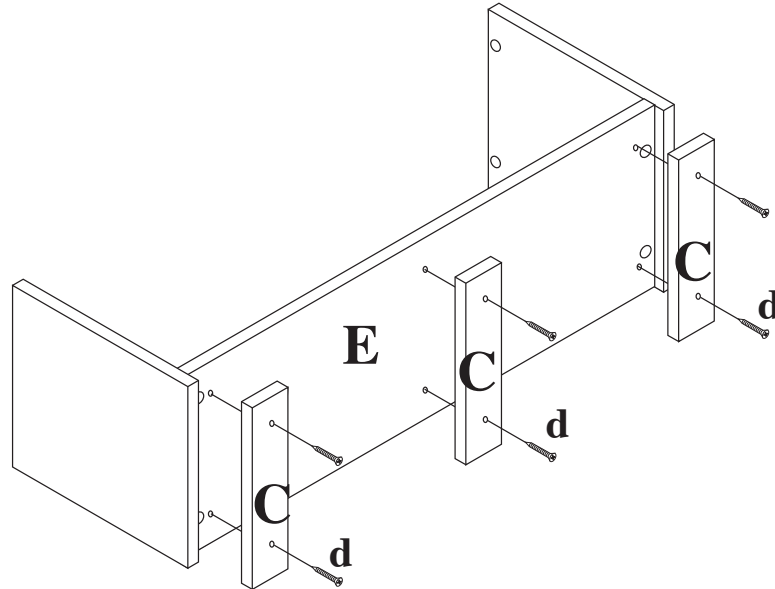

STEP 2-1 / PASO 2-1

FIX WOODEN DOWELS (c) AND BOLTS (a) INTO BOTTOM PANEL (E), AND THEN ATTACH MIDDLE BARS (D) ONTO BOTTOM PANEL (E) USING CAM LOCKS (b) AS SHOWN.

COLOQUE LAS CLAVIJAS DE MADERA (c) Y LOS PERNOS (a) EN EL PANEL INFERIOR (E), Y LUEGO COLOQUE LAS BARRAS MEDIAS (D) A TRAVÉS DEL PANEL INFERIOR (E) USANDO LAS LEVAS CON TRABAS (b) COMO SE MUESTRA

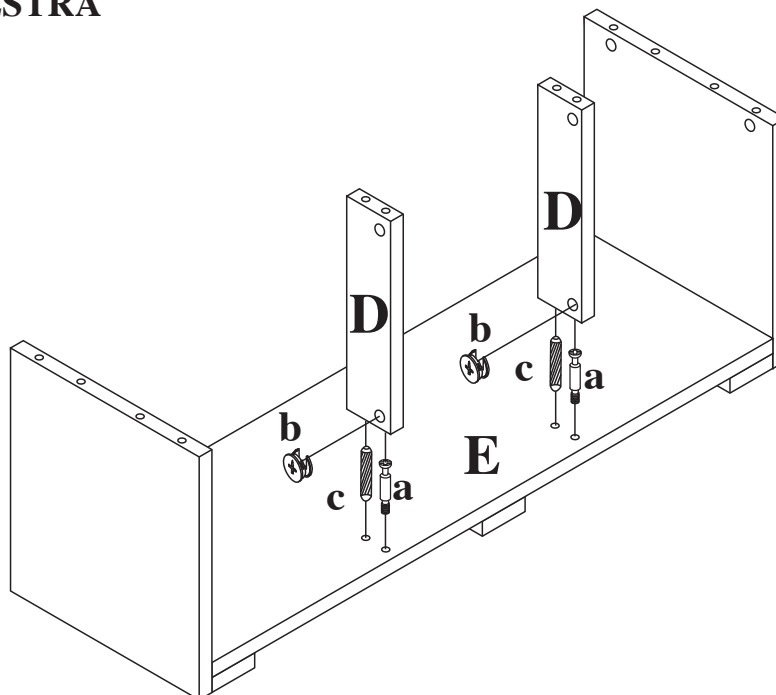

STEP 2-2 / PASO 2-2

FIX BOLTS (a) AND WOODEN DOWELS (c) INTO TOP PANEL (G) , AND THEN PUT TOP PANEL (G) ONTO LEFT SIDE PANEL (A) , MIDDLE BARS (D) AND RIGHT SIDE PANEL (B) LOCKING BY CAM LOCKS (b) AS SHOWN.

COLOQUE LOS PERNOS (a) Y LAS CLAVIJAS DE MADERA (c) EN EL PANEL SUPERIOR (G) , Y LUEGO COLOQUE EL PANEL SUPERIOR (G) AL PANEL LATERAL IZQUIERDO (A), BARRAS MEDIAS (D) Y EL PANEL LATERAL DERECHO (B) USANDO LAS LEVAS CON TRABAS (b) COMO SE MUESTRA.

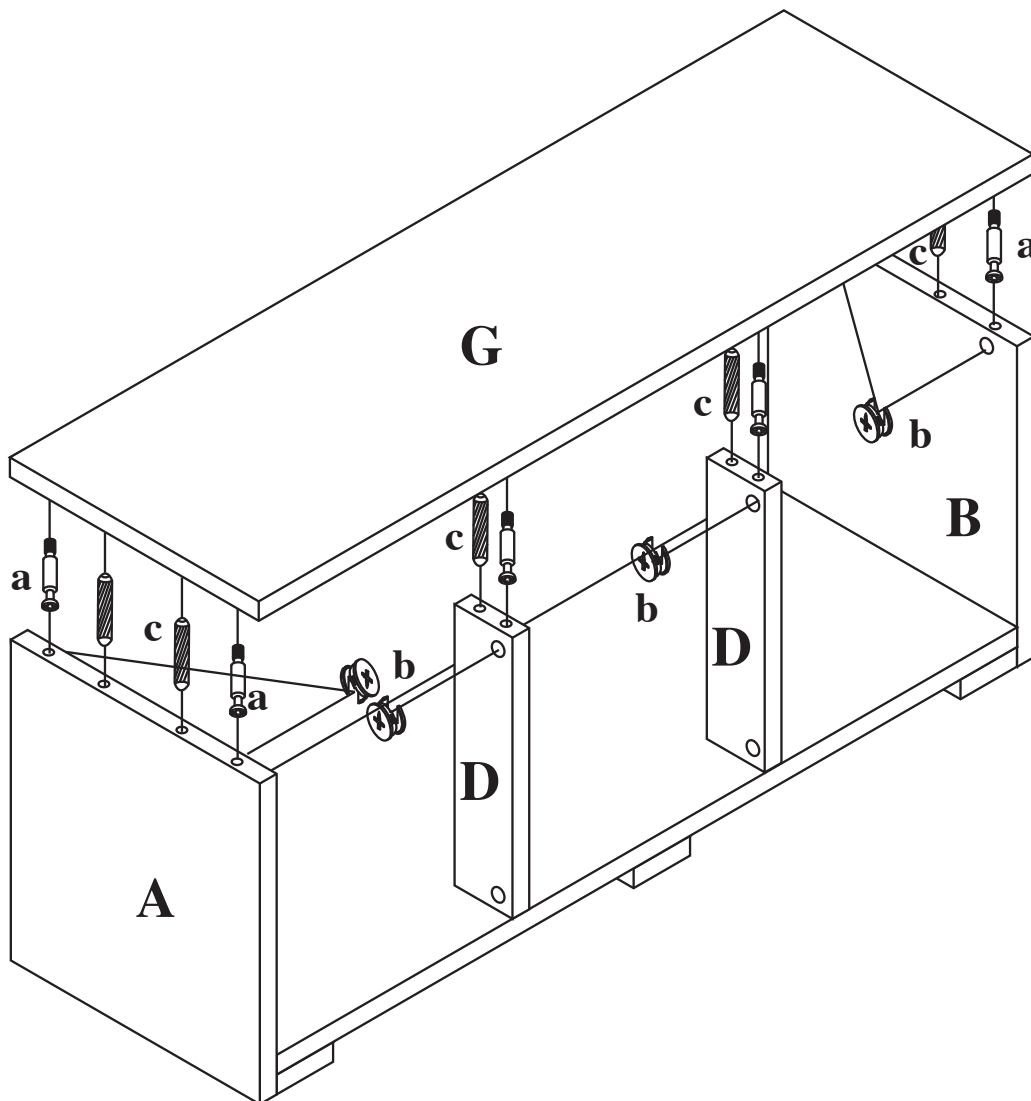

STEP 3 / PASO 3

ATTACH BACK PANEL (F) TO FINISHED STEP 2-2 USING SMALL SCREWS (e) AND PUT PINS (H) INTO SHELVES AS SHOWN.

ADJUNTE EL PANEL TRASERO (F) AL PASO 2-2 TERMINADO USANDO TORNILLOS CORTOS (e) Y COLOQUE LOS CAJONES (H) EN LOS ESTANTES COMO SE MUESTRA.

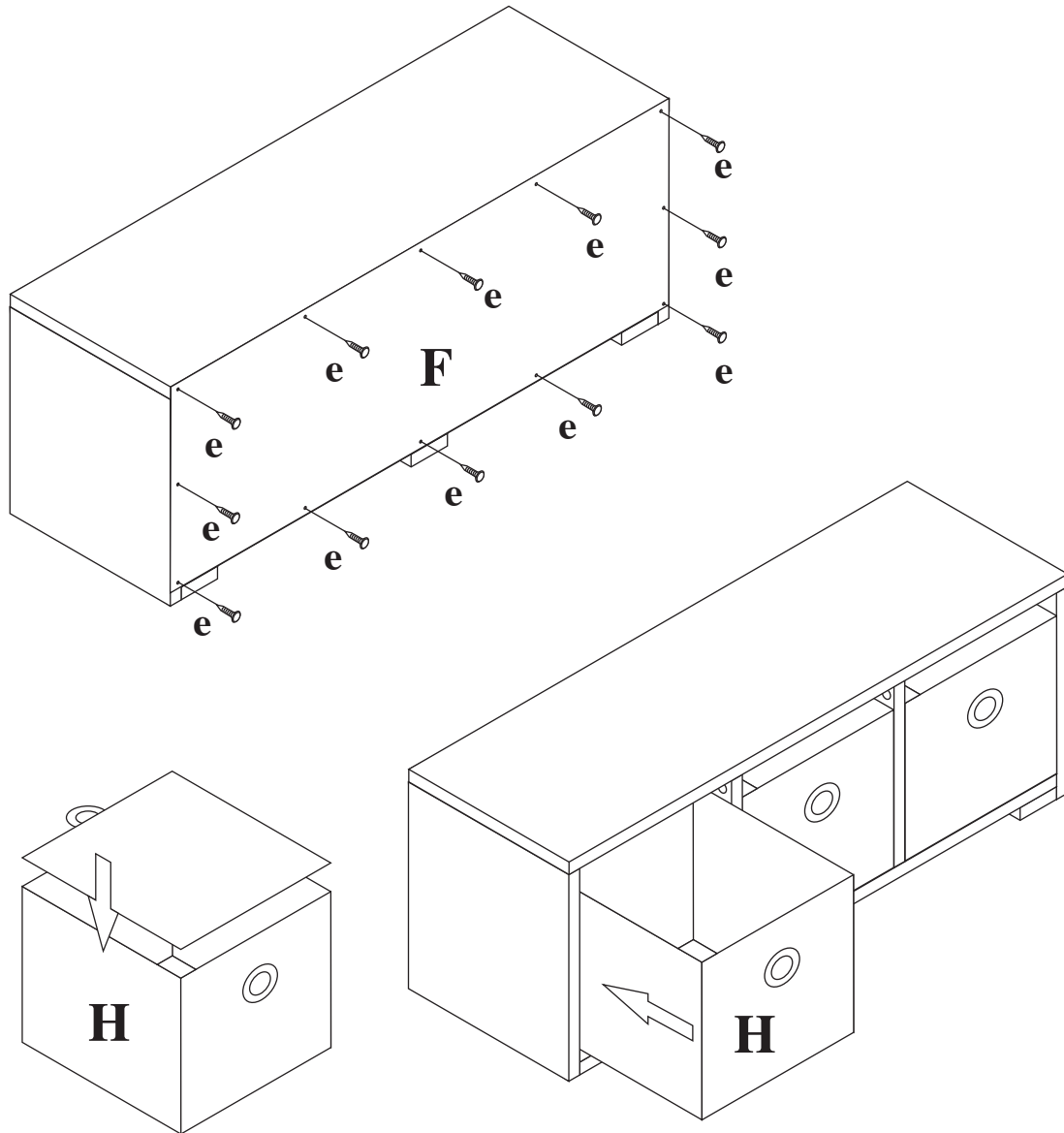

Do you have any questions ? Missing small parts or hardware ?
If you need assistance with the assembly of your WOODEN STORAGE BENCH WITH 3 BINS please e-mail our Customer Service

Department at: support@fourstari.com
or call us at (508) 473-7688 or (800) 639-3803

Please include the following information in your email:

- Where item was purchased
- Item, model, style or SKU number listed on instructions or box
- Part number, description of the part and quantity needed

This information will help us get the proper part to you faster

¿Tiene alguna pregunta? ¿Faltan piezas o accesorios pequeños?
Si necesita ayuda para ensamblar su BANCO CON ALMACENAMIENTO DE 3 CAJONES envíenos un correo electrónico a nuestro

Departamento de atención al cliente: ayuda@fourstari.com
o llámenos al (508) 473-7688 o al (800) 639-3803

Incluya la siguiente información en el correo electrónico:

- Dónde compró el producto
- El número de artículo, SKU, estilo, modelo o producto que aparece en las instrucciones o la caja
- El número y descripción de la pieza y la cantidad que necesita

Esta información nos ayudará a enviarle la pieza correcta con mayor rapidez