

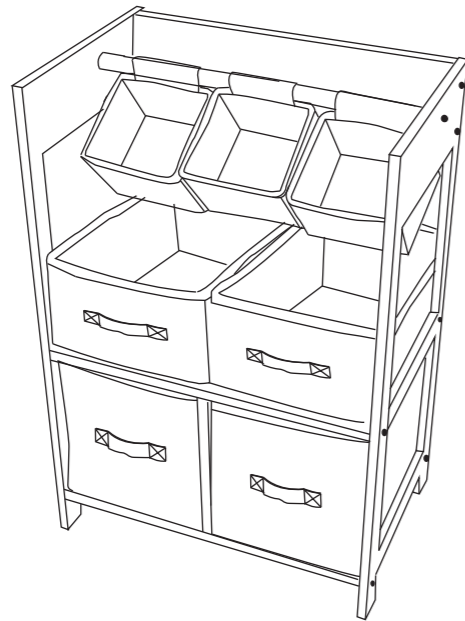

MODEL: 11223685
7 BIN WOODEN STORAGE ORGANIZER



- CAUTION :**
1. ADULT SUPERVISION IS REQUIRED DUE TO SMALL PARTS. CARE SHOULD BE TAKEN IN THE UNPACKING AND ASSEMBLING OF THIS PRODUCT.
 2. ASSEMBLE ON SOFT SURFACE TO PREVENT DAMAGE TO THE PRODUCT FINISH.
 3. MAKE SURE ALL PARTS ARE INCLUDED BEFORE ASSEMBLING.

BEFORE YOU BEGIN, PLEASE READ ASSEMBLY INSTRUCTIONS CAREFULLY. FOLLOW STEP BY STEP.

ASSEMBLY TOOLS REQUIRED

PHILIPS SCREWDRIVER



Do you have any questions? Missing small parts or hardware? If you need assistance with the assembly of your 7 BIN WOODEN STORAGE ORGANIZER please e-mail our Customer Service Department at: support@fourstari.com or call us at (800) 639-3803 or (508) 473-7688 if calling locally from Massachusetts area. Please include the following information in your email:
 • Where item was purchased • Item, model, style or SKU number listed on instructions or box • Part number, description of the part and quantity needed
 This information will help us get the proper part to you faster

PARTS LIST AND HARDWARE

NO	HARDWARE & PART LIST	QTY	NO	HARDWARE & PART LIST	QTY
A	SIDE FRAME	2 PCS	G	BIG BACK PANEL	1 PC
B	BOTTOM PANEL	1 PC	H	SCREW	10 PCS
C	VERTICAL BOARD	1 PC	I	BOLT	12 PCS
D	TOP PANEL	1 PC	J	MIDDLE BIN	2 PCS
E	CROSS BAR	1 PC	K	BIG BIN	2 PCS
F	SMALL BIN	3 PCS	L	SMALL BACK PANEL	2 PCS

ASSEMBLY INSTRUCTIONS

STEP 1
 PUT THE VERTICAL BOARD (C) IN THE GROOVE BETWEEN BOTTOM PANEL (B) AND TOP PANEL (D), COMBINE THEM BY USING SCREWS (H). PUT 2 SIDE FRAMES (A) ON LEFT AND RIGHT, USE BOLTS (I) TO COMBINE THEM TOGETHER. THEN ATTACH 2 SMALL BACK PANELS AT THE BACK OF THE FRAMES BY USING SCREWS (H) AS SHOWN.

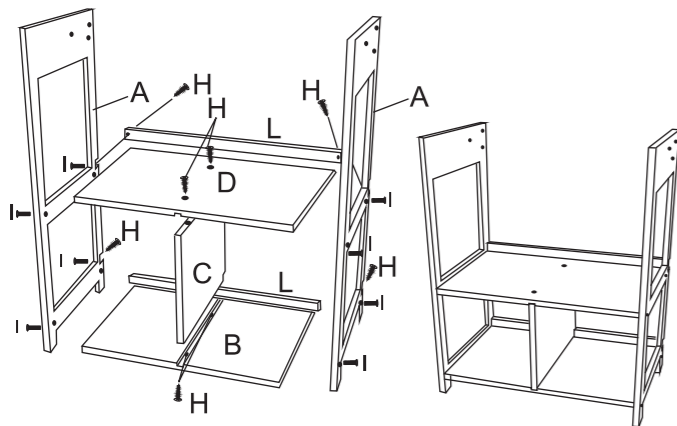

STEP 2
 INSERT THE CROSS BAR THROUGH THE 3 SMALL BINS ONE BY ONE, PUT IT BETWEEN THE LEFT FRAME AND RIGHT FRAME, USE SCREWS (H) TO TIGHTEN UP AS SHOWN.

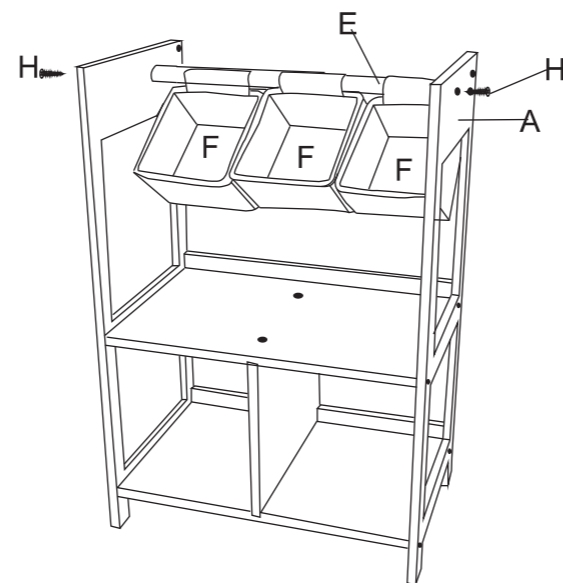

STEP 3
 PUT THE BIG BACK PANEL BETWEEN THE LEFT FRAME AND RIGHT FRAME, USE BOLTS (I) TO COMBINE AS SHOWN.

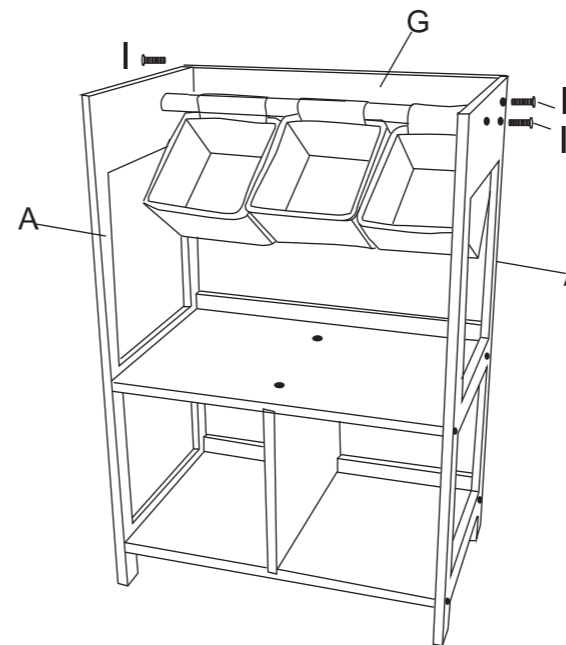

STEP 4
 INSERT THE MIDDLE BINS (J) ON THE TOP FLOOR AND BIG BINS (K) ON THE BOTTOM FLOOR AS SHOWN.

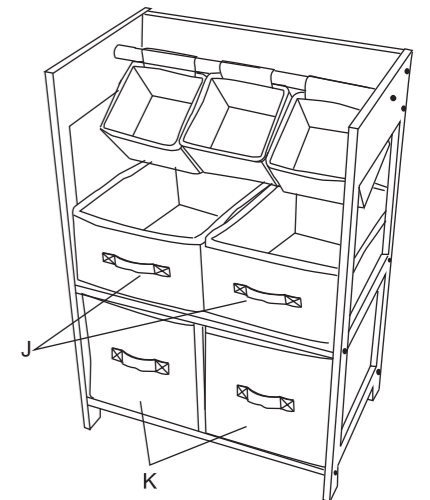

CAUTION:
 MAXIMUM LOADING CAPACITY IS 40 LBS.
 DO NOT SIT, STAND, LEAN, WALK OR JUMP! FAILURE TO COMPLY WITH THIS CAUTION COULD RESULT IN PERSONAL INJURY AND/OR PROPERTY DAMAGE!

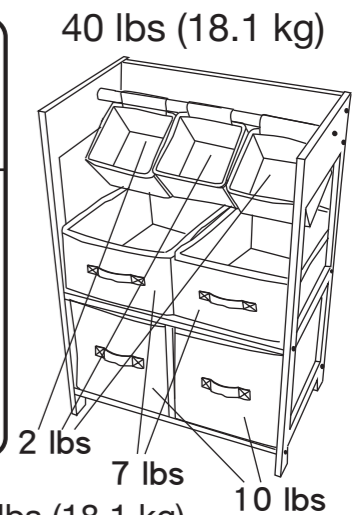

Weight Maximum 40 lbs (18.1 kg)



MODELO: 11223685
ORGANIZADOR DE MADERA DE 7 CAJONES DE TELA

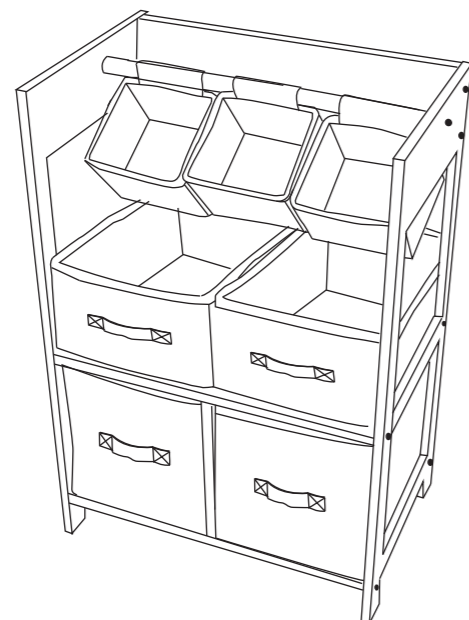

PRECAUCIÓN:

1. SE REQUIERE LA SUPERVISION DE UN ADULTO DEBIDO A LA EXISTENCIA DE PIEZAS PEQUEÑAS. DEBE TENER CUIDADO AL DESEMPACAR Y EN EL MONTAJE DE ESTE PRODUCTO.
2. ENSAMBLELO SOBRE SUPERFICIES SUAVES PARA EVITAR DAÑAR EL ACABADO DEL PRODUCTO.
3. ASEGURESE DE QUE ESTÉN TODAS LAS PIEZAS ANTES DEL MONTAJE.

ANTES DE COMENZAR, POR FAVOR LEA CUIDADOSAMENTE LAS INSTRUCCIONES DE MONTAJE. SEGUIRLAS PASO A PASO.





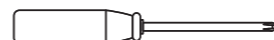







HERRAMIENTAS NECESARIAS

DESTORNILLADOR PHILLIPS



¿Tiene alguna pregunta? ¿Faltan piezas o accesorios pequeños? Si necesita ayuda para ensamblar su ORGANIZADOR DE MADERA DE 7 CAJONES DE TELA envíenos un correo electrónico a nuestro Departamento de atención al cliente: ayuda@fourstari.com o llámenos al (800) 639-3803 o (508) 473-7688 si llama desde la zona de Massachusetts Incluya la siguiente información en el correo electrónico:
 • Dónde compró el producto • El número de artículo, SKU, estilo, modelo o producto que aparece en las instrucciones o la caja • El número y descripción de la pieza y la cantidad que necesita
 Esta información nos ayudará a enviarle la pieza correcta con mayor rapidez

LISTA DE PARTES Y ACCESORIOS

NO	LISTA DE PARTES Y ACCESORIOS	CNT	NO	LISTA DE PARTES Y ACCESORIOS	CNT
A	SIDE FRAME 	2 PZS	G	BIG BACK PANEL 	1 PZ
B	BOTTOM PANEL 	1 PZ	H	SCREW 	10 PZS
C	VERTICAL BOARD 	1 PZ	I	BOLT 	12 PZS
D	TOP PANEL 	1 PZ	J	MIDDLE BIN 	2 PZS
E	CROSS BAR 	1 PZ	K	BIG BIN 	2 PZS
F	SMALL BIN 	3 PZS	L	SMALL BACK PANEL 	2 PZS

INSTRUCCIONES DE ENSAMBLAJE

PASO 1
 PONER LA TABLA VERTICAL (C) EN LA RANURA ENTRE EL PANEL INFERIOR (B) Y EL PANEL SUPERIOR (D), QUE SE COMBINAN POR MEDIO DE TORNILLOS (H). PONGA DOS TRAVESAÑOS LATERALES (A) EN LA IZQUIERDA Y LA DERECHA, UTILIZAR PERNOS (I) PARA COMBINARLOS. A CONTINUACIÓN, CONECTE DOS PANELES TRASEROS PEQUEÑOS EN LA PARTE POSTERIOR DE LA ESTRUCTURA MEDIANTE EL USO DE TORNILLOS (H), COMO SE MUESTRA.

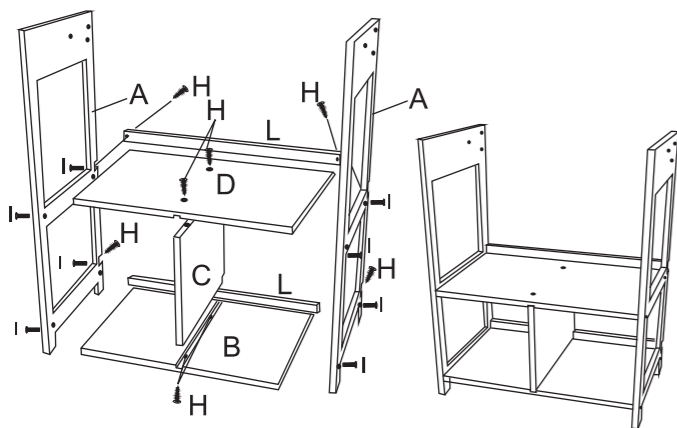

PASO 2
 INSERTE EL TRAVESAÑO A TRAVES DE LOS 3 CAJONES PEQUEÑOS UNO POR UNO ENTRE EL MARCO IZQUIERDO Y DERECHO, UTILIZANDO TORNILLOS (H) PARA AJUSTAR COMO SE MUESTRA.

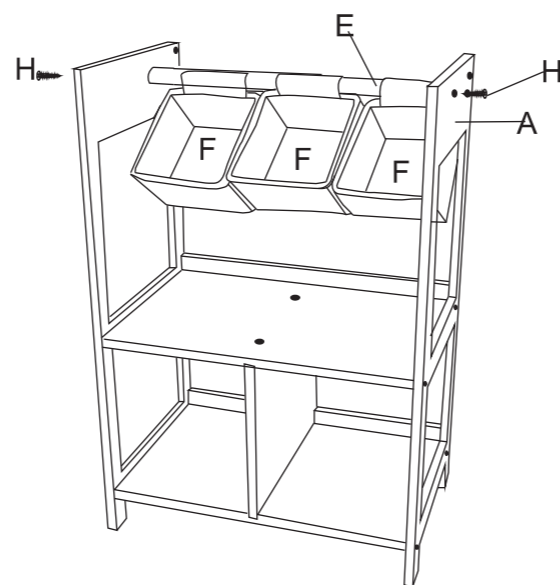

PASO 3
 COLOQUE EL PANEL TRASERO GRANDE AL MARCO IZQUIERDO Y DERECHO, USE LOS PERNOS (I) PARA COMBINARLOS COMO SE MUESTRA.

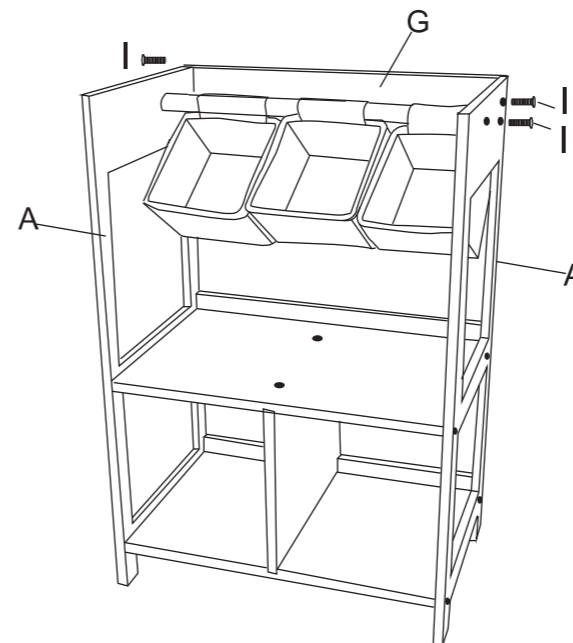

PASO 4
 INSERTE LOS CAJONES MEDIOS (J) AL ESTANTE SUPERIOR Y LOS CAJONES GRANDES (K) AL ESTANTE INFERIOR COMO SE MUESTRA.

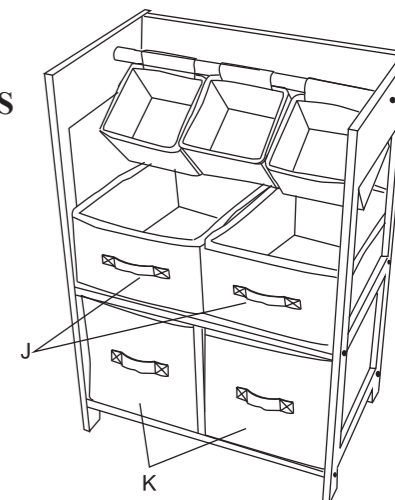

PRECAUCIÓN:
 LA CARGA MÁXIMA ES DE 40 LBS.

NO SENTARSE, PARARSE, APOYARSE, CAMINAR O SALTAR! EL INCUMPLIMIENTO PUEDE RESULTAR EN LESIONES PERSONALES Y / O DAÑOS A LA PROPIEDAD!

Peso Maximo 40 lbs (18,1 kg)

40 lbs (18,1 kg)

