

MODEL: 11222719 4 DRAWER ORGANIZER

BEFORE YOU BEGIN, PLEASE READ ASSEMBLY INSTRUCTIONS CAREFULLY. FOLLOW THEM STEP BY STEP.

ASSEMBLY TOOLS REQUIRED
RUBBER Mallet
PHILIPS SCREWDRIVER

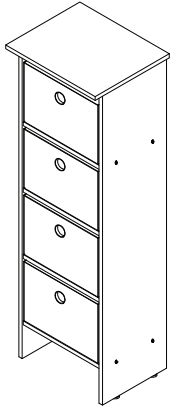

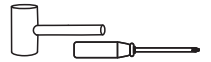





CAUTION :





1. ADULT SUPERVISION IS REQUIRED DUE TO SMALL PARTS. CARE SHOULD BE TAKEN IN THE UNPACKING AND ASSEMBLY OF THE PRODUCT.
2. ASSEMBLE ON SOFT SURFACES TO PREVENT DAMAGE TO THE PRODUCT FINISH.
3. MAKE SURE ALL PARTS ARE INCLUDED BEFORE ASSEMBLY.

Do you have any questions? Missing small parts or hardware? If you need assistance with the assembly of your 4 DRAWER ORGANIZER please e-mail our Customer Service Department at: support@fourstari.com or call us at (800) 639-3803 or (508) 473-7688 if calling locally from Massachusetts area

Please include the following information in your email:

- Where item was purchased • Item, model, style or SKU number listed on instructions or box • Part number, description of the part and quantity needed
- This information will help us get the proper part to you faster

| NO | HARDWARE LIST | QTY |
|----|---|--------|
| 1 | CHIPBOARD SCREW  | 8 PCS |
| 2 | PLASTIC DOWEL  | 12 PCS |
| 3 | POWER PIN  | 5 PCS |
| 4 | NAIL LEG  | 4 PCS |
| 5 | NON WOVEN BIN  | 4 PCS |
| 6 | SCREW COVER STICKER  | 1 Set |
| 7 | WHITE GLUE 1 PC  | 1 PC |

| NO | PARTS LIST | QTY |
|----|---|-------|
| A | TOP PANEL  | 1 PC |
| B | SIDE PANEL  | 2 PCS |
| C | 1st/4th SHELF PANEL  | 2 PCS |
| D | 2nd/3rd SHELF PANEL  | 2 PCS |
| E | BACK PANEL  | 1 PC |

ASSEMBLY INSTRUCTIONS

STEP 1
INSERT PLASTIC DOWEL (2) TO PANEL (B) (D) WITH GLUE (7).

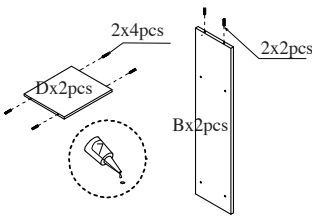

STEP 2
FACE DOWN THE TOP PANEL(A) ON SMOOTH SURFACE TO PREVENT SCRATCHES.
ATTACH SIDE PANEL(B) TO UNFINISHED SURFACE OF TOP PANEL(A) WITH GLUE 7.

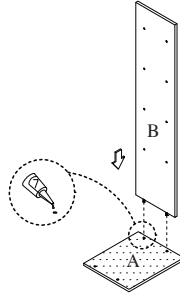

STEP 3
ATTACH SHELF PANEL(D) TO SIDE PANEL(B) WITH GLUE (7).

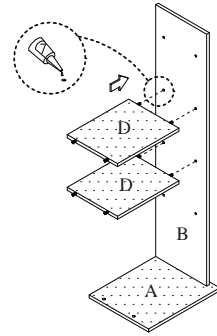

STEP 4
ATTACH ANOTHER OF SIDE PANEL(B) TO IT WITH GLUE(7).

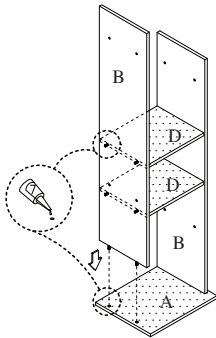

STEP 5
FASTEN THE SHELF(C) TO SIDE PANEL(B) WITH SCREW(1).

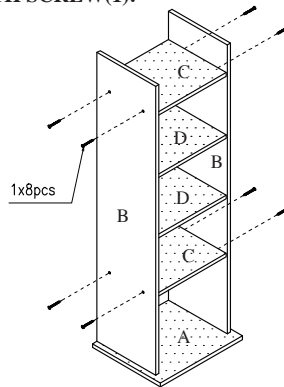

STEP 6
INSTALL NAIL LEG(4) TO THE BOTTOM OF SIDE PANEL(B) WITH HAMMER.

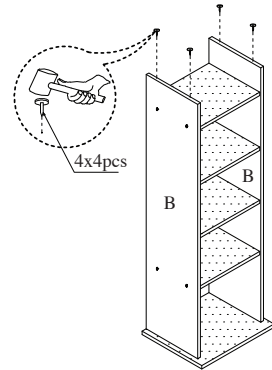

STEP 7
PLACE THE STORAGE FACE DOWN, ATTACH THE BACK PANEL (E) ON BACK AND FASTEN WITH POWER PIN(3).

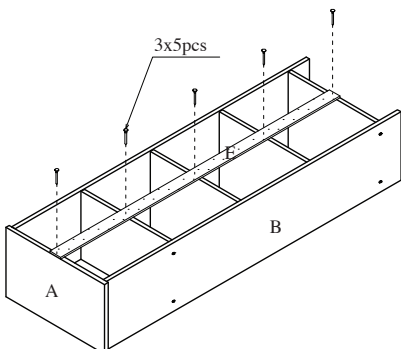

STEP 8
8.1 UNFOLD THE BIN (5) AND SLIDE INTO THE STORAGE.
8.2 COVER THE SCREW POSITION WITH STICKER.

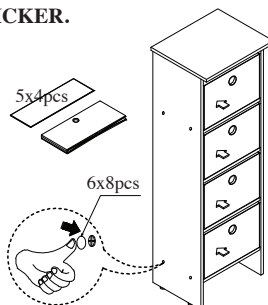

Shelf weight limit:
20 lbs. (9.07 kg)

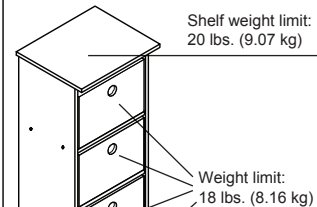

Weight limit:
18 lbs. (8.16 kg)

This unit is intended for use only with the products and maximum weights indicated. Use with other products or products heavier than the maximum weights indicated may result in instability causing possible injury. Furniture can tip over or break if improperly moved. Have a friend help to lift and carry the unit to its new location.

MODELO: 11222719

ORGANIZADOR DE 4 CAJONES

ANTES DE EMPEZAR, POR FAVOR LEA LAS INSTRUCCIONES DE MONTAJE. SIGALAS PASO A PASO.

HERRAMIENTAS NECESARIAS

MARTILLO

DESTORNILLADOR PHILIPS

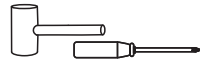

PRECAUCION:

1. LA SUPERVISION DE UN ADULTO ES REQUERIDA DEBIDO A PARTES PEQUEÑAS. TENGA CUIDADO EN EL DESEMBALAJE Y MONTAJE DEL PRODUCTO
2. ARME ESTE PRODUCTO EN UNA SUPERFICIE LISA, PARA PREVENIR DAÑOS AL TERMINADO DE ESTE PRODUCTO.
3. ASEGURESE DE QUE TODAS LAS PARTES ESTEN INCLUIDAS ANTES DE COMENZAR.

¿Tiene alguna pregunta? ¿Faltan piezas o accesorios pequeños? Si necesita ayuda para ensamblar su ESTANTE ORGANIZADOR DE 6 CAJONES envíenos un correo electrónico a nuestro Departamento de atención al cliente: ayuda@fourstari.com o llámenos al (800) 639-3803 o al (508) 473-7688

Incluya la siguiente información en el correo electrónico:

- Dónde compró el producto
- El número de artículo, SKU, estilo, modelo o producto que aparece en las instrucciones o la caja
- El número y descripción de la pieza y la cantidad que necesita

Esta información nos ayudará a enviarle la pieza correcta con mayor rapidez

| NO | LISTA DE ACCESORIOS | CNT |
|----|--------------------------------|--------|
| 1 | TORNILLO DE MADERA | 8 PZS |
| 2 | CLAVIJA DE PLASTICO | 12 PZS |
| 3 | CLAVOS | 5 PZS |
| 4 | CLAVOR CON PATA | 4 PZS |
| 5 | CAJON DE TELA | 4 PZS |
| 6 | CUBRE TORNILLOS AUTO-ADHESIVOS | 1 CON. |
| 7 | PEGAMENTO | 1 PZ |

| NO | LISTA DE PARTES | CNT |
|----|--------------------------|-------|
| A | PANEL SUPERIOR | 1 PZ |
| B | PANEL LATERAL | 2 PZS |
| C | 1st/4th PANEL LATERAL -R | 2 PZS |
| D | 2nd/3rd PANEL DE ESTANTE | 2 PZS |
| E | PANEL TRASERO | 1 PZ |

INSTRUCCIONES DE MONTAJE

PASO 1
INSERTE LAS CLAVIJAS DE PLASTICO (2) AL PANEL (B)(D) CON PEGAMENTO (7).

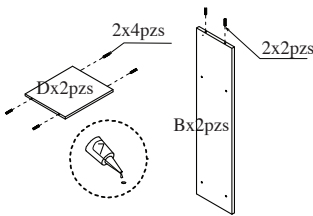

PASO 2
COLOQUE EL PANEL SUPERIOR (A) BOCA ABAJO, EN UNA SUPERFICIE LISA, PARA PREVENIR DAÑOS AL TERMINADO DE ESTE PRODUCTO.
ADJUNTE EL PANEL LATERAL (B) A LA SEUPERFICIE SIN TERMINAR DEL PANEL SUPERIOR (A) CON PEGAMENTO (7).

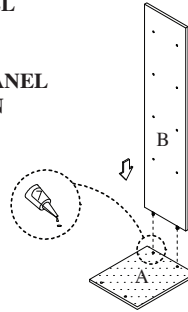

PASO 3
ADJUNTE LOS ESTANTES (D) AL PANEL LATERAL CON PEGAMENTO (7).

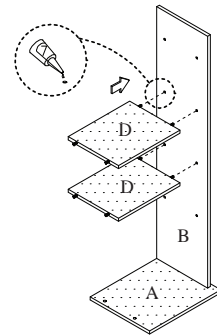

PASO 4
ADJUNTE EL OTRO LADO DEL PANEL LATERAL (B) A ESTA ESTRUCTURA CON PEGAMENTO (7).

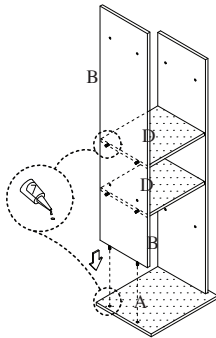

PASO 5
AJUSTE LOS ESTANTES (C) AL PANEL LATERAL(B) CON TORNILLOS (1).

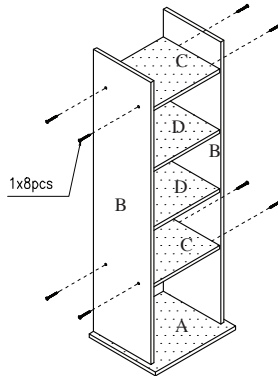

PASO 6
INSTALE LAS PATAS CON CLAVO (4) A LOS COSTADOS DEL PANEL INFERIOR (B) CON MARTILLO.

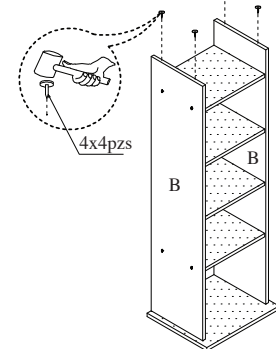

PASO 7
COLOQUE EL PRODUCTO BOCA ABAJO, ADJUNTE EL PANEL TRASERO (E) A LA PARTE TRASERA CON LOS CLAVOS (3).

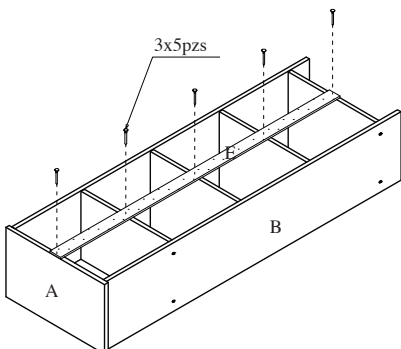

PASO 8
8.1
DESDOBLE LOS CAJONES (5) Y COLOQUELOS EN LOS ESTANTES.
8.2
CUBRA LOS ORIFICIOS DE LOS TORNILLOS CON LOS AUTO-ADHESIVOS CORRESPONDIENTES (6).

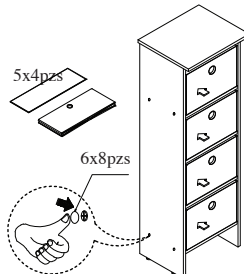

Capacidad máxima del estante:
20 lbs. (9.07 kg)

Capacidad máxima del estante:
18 lbs. (8.16 kg)

Esta unidad está destinada sólo para su uso con los productos y pesos máximos indicados. Si usted utiliza esta mesa con otros productos o de los productos más pesados que el peso máximo indicado, puede causar inestabilidad y puede dar lugar a posibles lesiones. La mesa puede volcarse o romperse si es trasladada indebidamente. Se sugiere tener un amigo para que le ayude a levantar y transportar la mesa a su nueva ubicación.