

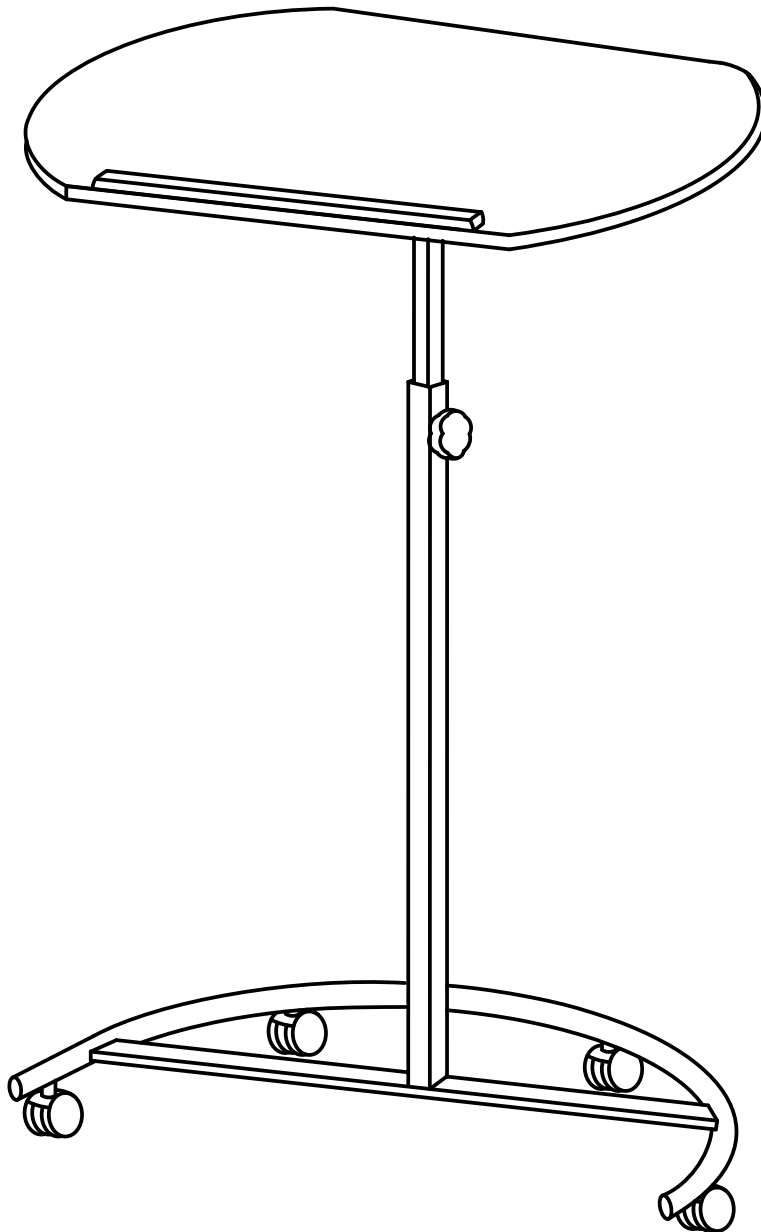











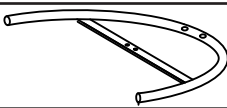
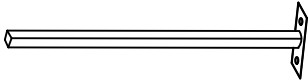



fourstargroup



MODEL: 11222236FZ / MODELO: 11222236FZ

**LAPTOP PODIUM**  
**PODIO PARA LAPYOP**

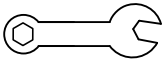
# PARTS AND HARDWARE LISTA DE PARTES Y HARDWARE

NO	HARDWARE LIST LISTA DE HARDWARE	QTY CNT
A	SUPPORT BASE BASE DE SOPORTE 	1 PC 1 PZ
B	LOWER SUPPORT BAR BARRA DE SOPORTE INFERIOR 	1 PC 1 PZ
C	UPPER SUPPORT BAR BARRA DE SOPORTE SUPERIOR 	1 PC 1 PZ
D	TILT PLATE PLACA DE INCINACION 	1 PC 1 PZ
E	LINK CONECTOR 	2 PCS 2 PZS
F	TOP PANEL PANEL SUPERIOR 	1 PC 1 PZ
G	BOLT 25MM TORNILLO 25MM 	2 PCS 2 PZS
H	BOLT 10MM TORNILLO 10MM 	6 PCS 6 PZS
I	NUT TUERCA 	2 PCS 2 PZS
J	HEAD BOLT (6MM) PERNO (6MM) 	1 PC 1 PZ
K	HEAD BOLT (8MM) PERNO (8MM) 	1 PC 1 PZ
L	WASHER ARANDELA 	1 PC 1 PZ
M	CASTOR RUEDA 	2 PCS 2 PZS
N	LOCKING CASTOR RUEDA CON TRABA 	2 PCS 2 PZS
O	WRENCH LLAVE 	1 PC 1 PZ
P	ALLEN WRENCH LLAVE ALLEN 	1 PC 1 PZ

# ASSEMBLY INSTRUCTIONS INSTRUCCIONES DE ASAMBLE

## CAUTION:

1. READ THIS INSTRUCTION MANUAL BEFORE YOU ASSEMBLE.
2. ASSEMBLE ON SOFT SURFACE TO PREVENT DAMAGE TO FINISH OF PRODUCT.

## PRECAUCION:

1. LEA ESTE MANUAL DE INSTRUCCIONES ANTES DE ARMAR.
2. ARME ESTE PRODUCTO EN UNA SUPERFICIE BLANDA, PARA PREVENIR DAÑOS AL TERMINADO DE ESTE PRODUCTO.

## STEP 1

ATTACH CASTORS (M) AND LOCKING CASTORS (N) TO SUPPORT BASE (A) WITH WRENCH (O) AS SHOWN.

\*DO NOT TIGHTEN THE BOLTS AT THIS TIME.

## PASO 1

ADJUNTE LAS RUEDAS (M) Y LAS RUEDAS CON TRABA (N) AL SOPORTE DE LA BASE (A) CON LA LLAVE (O) COMOS SE DEMUESTRA.

\* NO AJUSTE LOS TORNILLOS TOTALMENTE EN ESTE MOMENTO.

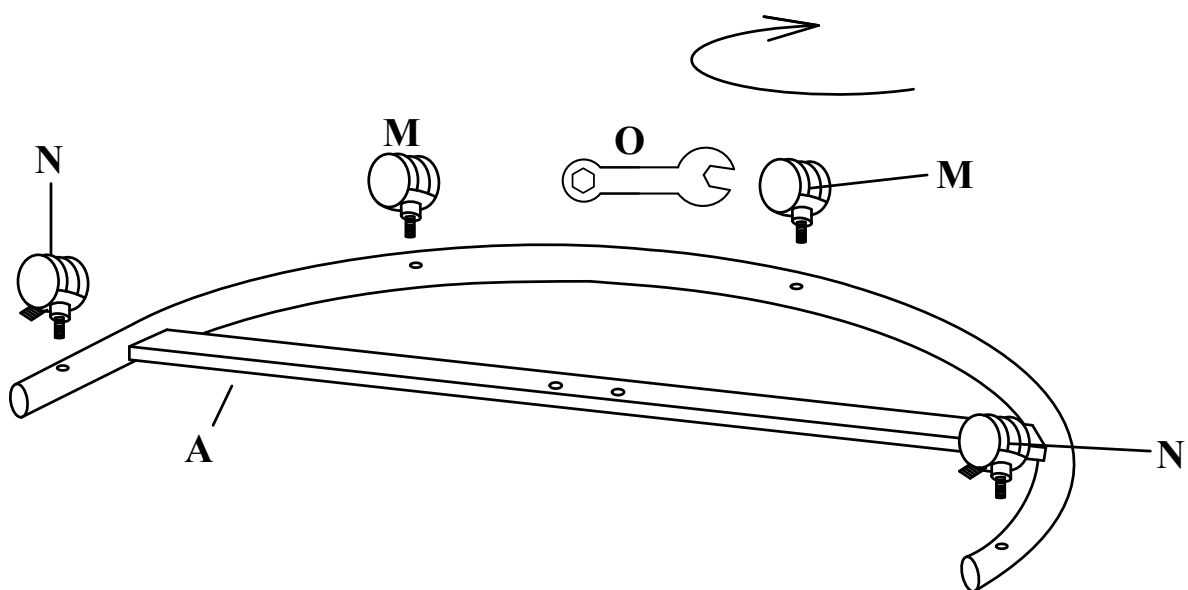

## STEP 2

**ATTACH LOWER SUPPORT BAR (B) TO SUPPORT BASE (A) USING BOLTS (G) AND NUTS (I) WITH PROVIDED ALLEN WRENCH (P) AND WRENCH (O) AS SHOWN.**

## PASO 2

**ADJUNTE LA BARRA DE SOPORTE INFERIOR (B) AL SOPORTE DE BASE (A) UTILIZANDO LOS TORNILLOS (G) Y TUERCAS (I) CON LA LLAVE ALLEN (P) Y LA LLAVE (O) COMO SE DEMUESTRA.**

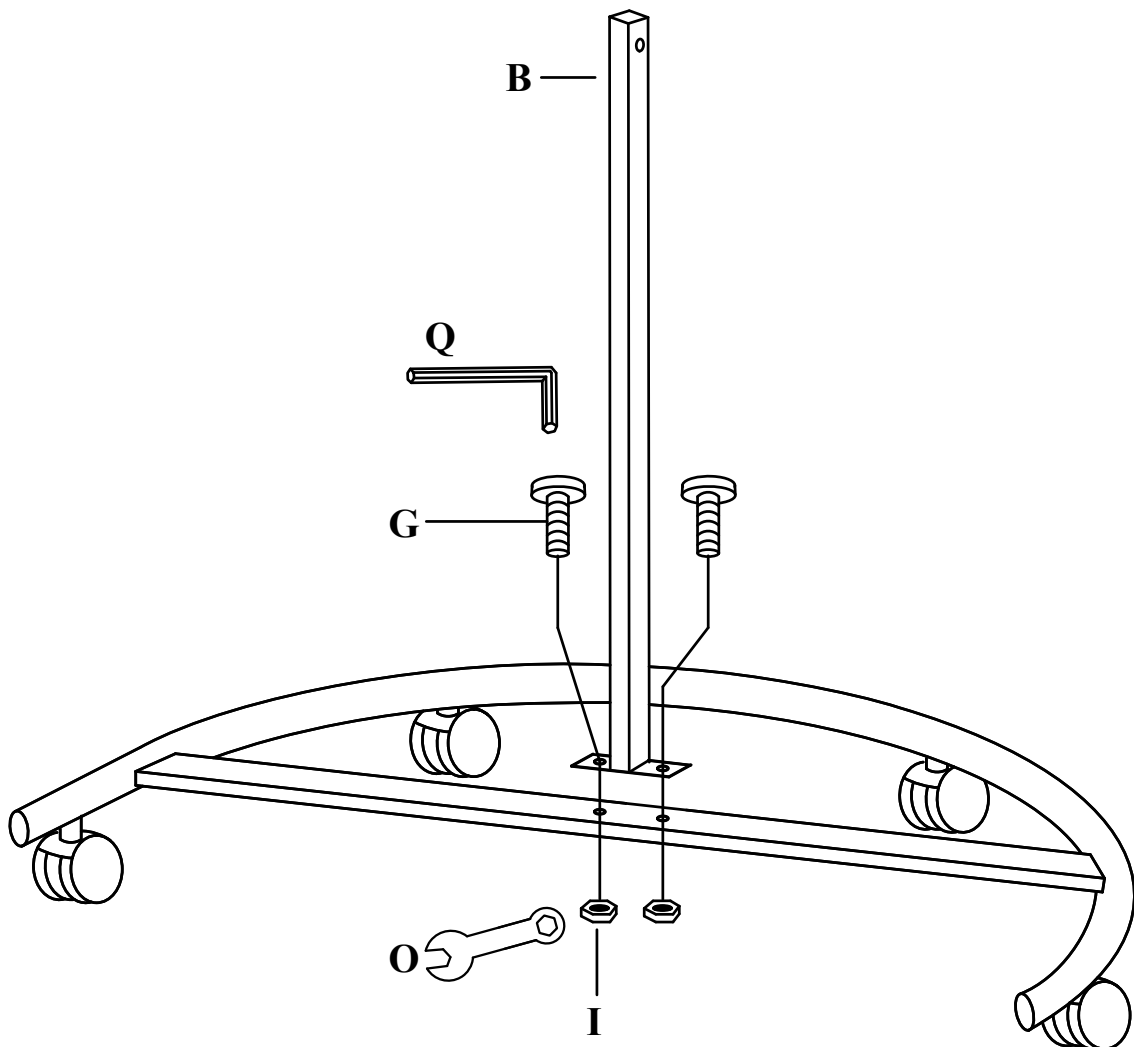

### STEP 3

**ATTACH TILT PLATE (D) TO UPPER SUPPORT BAR (C) USING WASHER (L) AND HEAD BOLT (K) AS SHOWN.**

### PASO 3

**AÑADA LA PLACA DE INCLINACION (D) A LA BARRA SUPERIOR DE SOPORTE (C) UTILIZANDO LA ARANDELA (L) Y EL TORNILLO (K) COMO SE DEMUESTRA.**

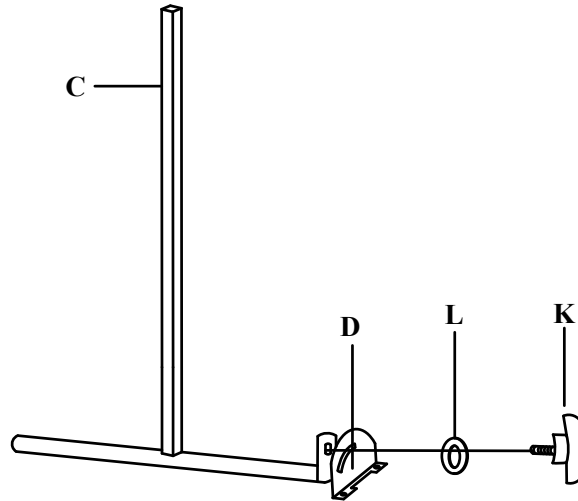

### STEP 4

**ATTACH UPPER SUPPORT BAR (C) TO TOP PANEL (F) USING LINKS (E) AND BOLTS (H) WITH PROVIDED ALLEN WRENCH (P) AS SHOWN.**

### PASO 4

**ADJUNTE LA BARRA SUPERIOR DE SOPORTE (C) AL PANEL SUPERIOR (F) UTILIZANDO LOS CONECTORES (E) Y TORNILLOS (H) CON LA LLAVE ALLEN (P) COMO SE DEMUESTRA.**

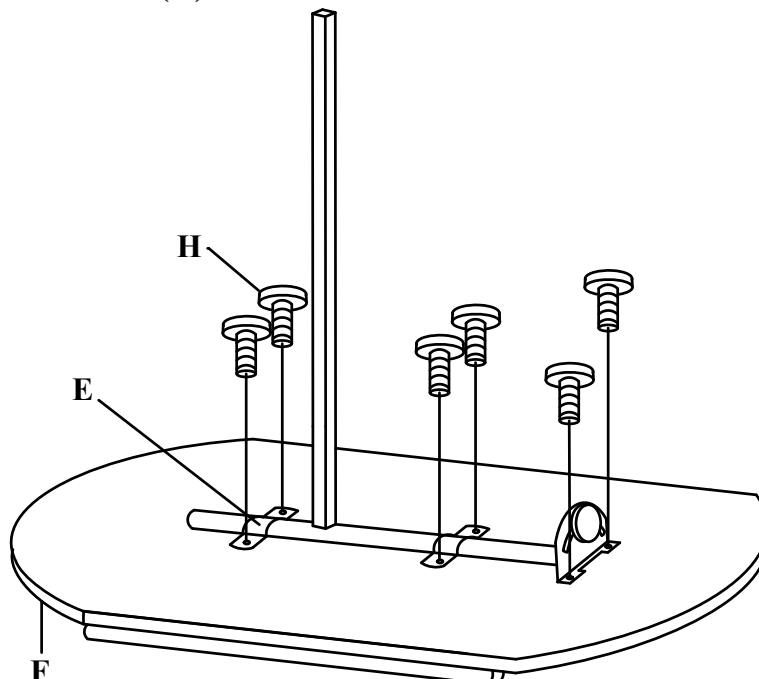

## STEP 5

**ATTACH STEP 4 COMPLETED ASSEMBLY TO STEP 2 COMPLETED ASSEMBLY USING HEAD BOLT (J) AS SHOWN.**

**\*TIGHTEN ALL BOLTS AT THIS TIME.**

## PASO 5

**AÑADE EL PASO 4 COMPLETO AL PASO 2 COMPLETO UTILIZANDO EL TORNILLO (J) COMOS SE DEMUESTRA .**

**\* AJUSTE LOS TORNILLOS TOTALMENTE EN ESTE MOMENTO.**

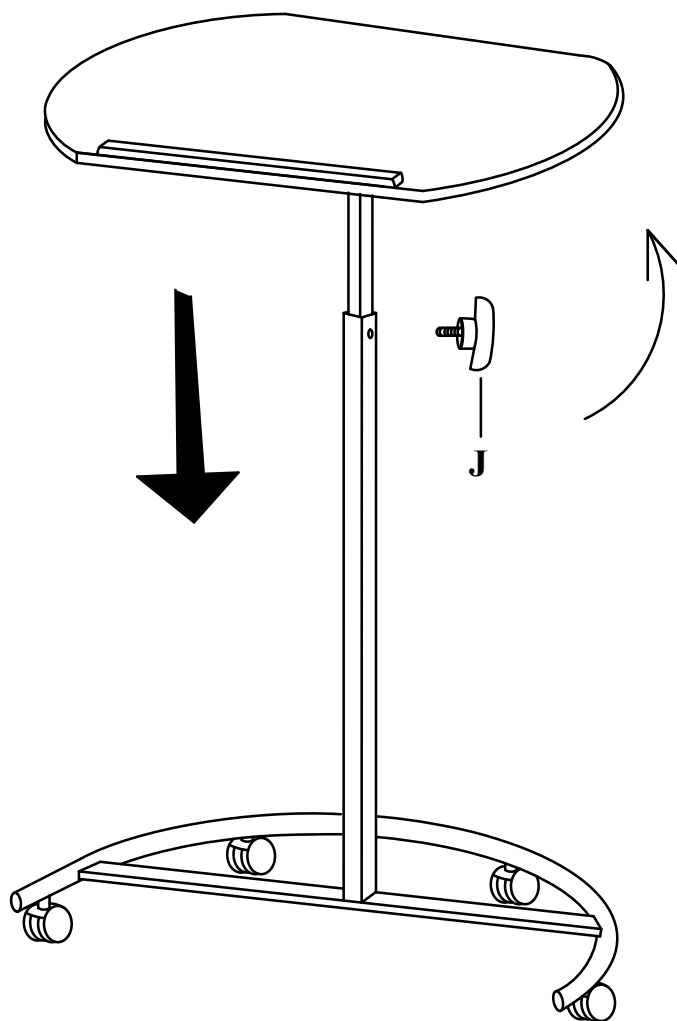

Do you have any questions? Missing small parts or hardware?  
If you need assistance with the assembly of your LAPTOP PODIUM please e-mail our Customer Service Department at: [support@fourstari.com](mailto:support@fourstari.com) or call us at (508) 473-7688 or (800) 639-3803  
Please include the following information in your email:

- Where item was purchased
- Item, model, style or SKU number listed on instructions or box
- Part number, description of the part and quantity needed

This information will help us get the proper part to you faster

¿Tiene alguna pregunta? ¿Faltan piezas o accesorios pequeños?  
Si necesita ayuda para ensamblar su PODIO PARA LOPYOP envíenos un correo electrónico a nuestro Departamento de atención al cliente: [ayuda@fourstari.com](mailto:ayuda@fourstari.com) o llámenos al (508) 473-7688 o al (800) 639-3803  
Incluya la siguiente información en el correo electrónico:

- Dónde compró el producto
- El número de artículo, SKU, estilo, modelo o producto que aparece en las instrucciones o la caja
- El número y descripción de la pieza y la cantidad que necesita

Esta información nos ayudará a enviarle la pieza correcta con mayor rapidez