

ITEM# 11222150VW
SIZE: 21L X 29.7H(CM)

CUSTOMER	ITEM NO.	ITEM DESCRIPTION	A/W NO.	MDSER	DESIGNER	DATE
VW	11222150VW	3 PIECE GLASS/METAL LEAF TABLES	0912014	Black	Ariel	2009 12/09

This proprietary artwork and concepts are copyright designs of Fourstar Group Inc. 2009. No part of this artwork may be reproduced or transmitted in any form without prior approval or consent.

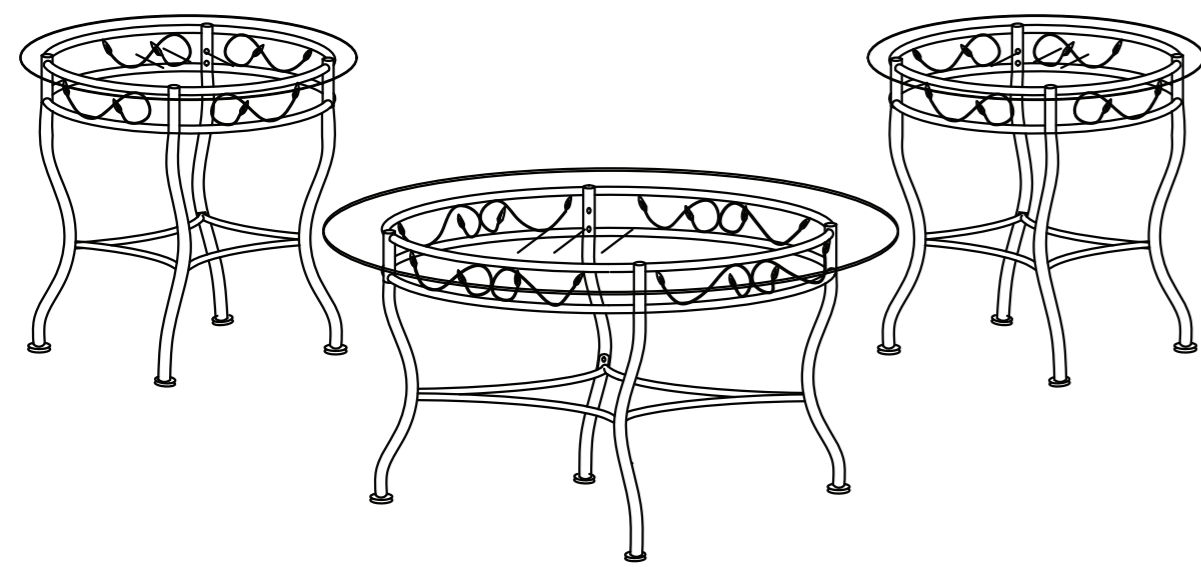

MODEL: 11222150VW
3 PIECE TABLE SET

PARTS LIST AND HARDWARE

A		END TABLE FRAME	2PCS
B		END TABLE LEG	8PCS
C		END TABLE BAR	2PCS
D		COFFEE TABLE FRAME	1PC
E		COFFEE TABLE LEG	4PCS
F		COFFEE TABLE BAR	1PC
G		END TABLE GLASS TOP	2PCS
H		COFFEE TABLE GLASS TOP	1PC
I		BOLT	36PCS
J		SUCTION CUP	12PCS
K		ALLEN WRENCH	1PC

ASSEMBLY INSTRUCTIONS

STEP 1
INSERT END TABLE LEG (B) TO END TABLE FRAME (A) AS SHOWN.

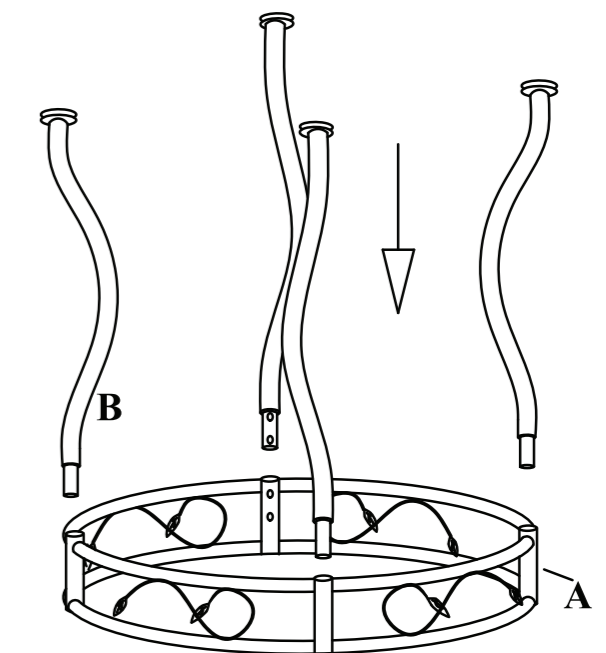

STEP 2
SCREW END TABLE LEGS (B) TO END TABLE FRAME (A) USING BOLTS (I).

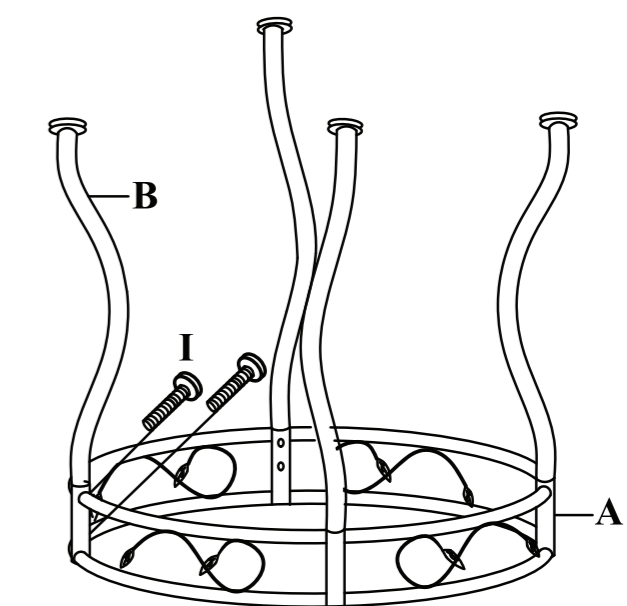

IMPORTANT: DO NOT TIGHTEN BOLTS AT THIS TIME

STEP 3
ATTACH END TABLE BAR (C) TO EACH LEG USING BOLT (I).

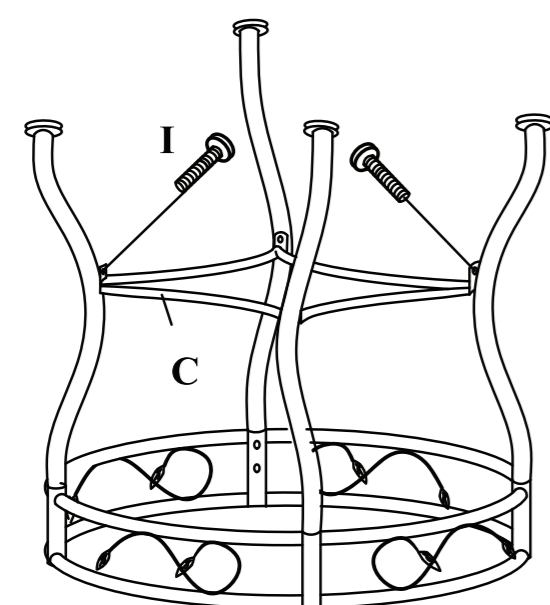

IMPORTANT: TIGHTEN ALL BOLTS

STEP 4
PLACE SUCTION CUP (J) ON TABLE FRAME AND PUT END TABLE GLASS TOP (G) ONTO THE TABLE FRAME AS SHOWN.

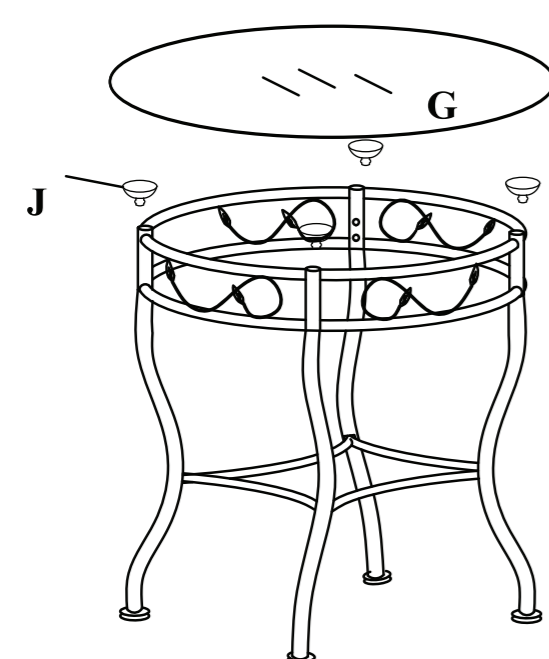

STEP 5
INSERT COFFEE TABLE LEGS (E) TO COFFEE TABLE FRAME (D) AS SHOWN.

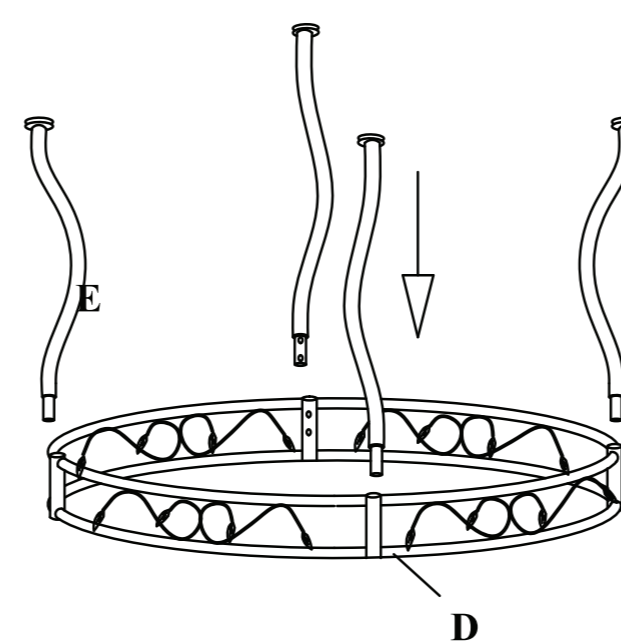

STEP 6
SCREW COFFEE TABLE LEGS (E) TO END TABLE FRAME (D) USING BOLTS (I).

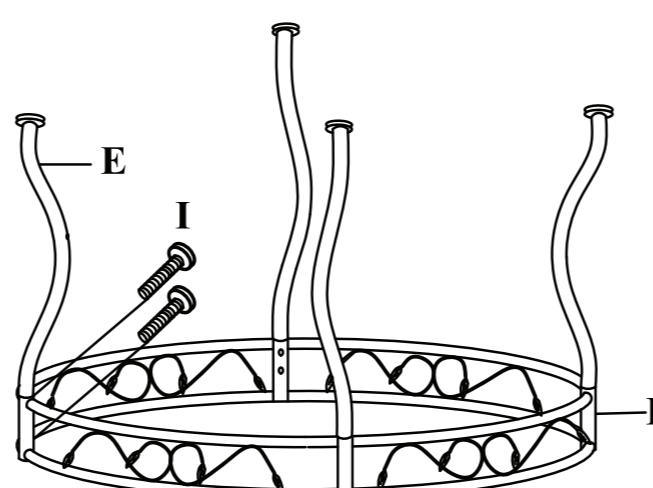

IMPORTANT: DO NOT TIGHTEN BOLTS AT THIS TIME

STEP 7
ATTACH COFFEE TABLE BAR (F) TO EACH LEG USING BOLT (I).

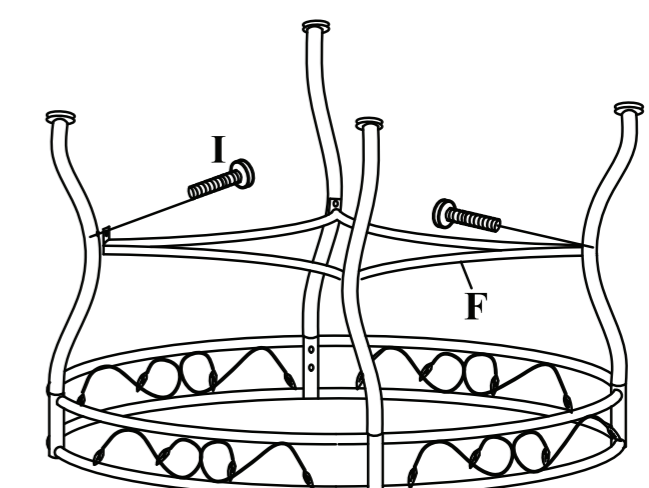

IMPORTANT: TIGHTEN ALL BOLTS

STEP 8
PLACE SUCTION CUP (J) ON TABLE FRAME AND PUT COFFEE TABLE GLASS TOP (H) ONTO THE TABLE FRAME AS SHOWN.

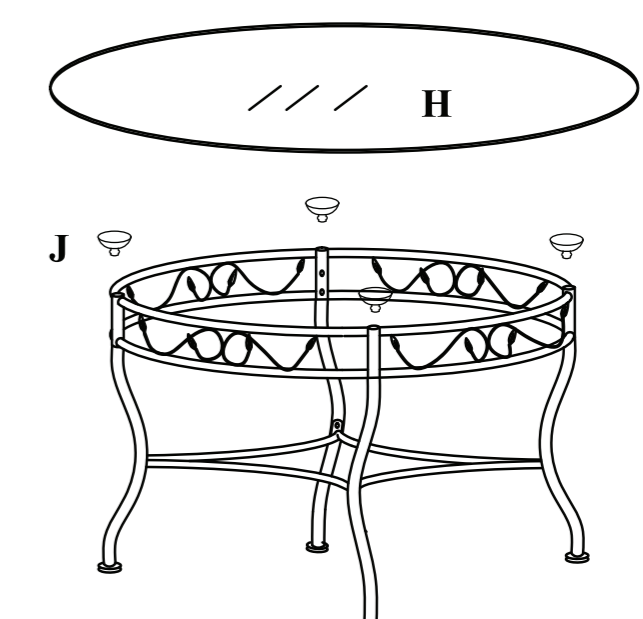

Do you have any questions? Missing small parts or hardware?
 If you need assistance with the assembly of your 3 PIECE TABLE SET please e-mail our Customer Service Department at: support@fourstari.com or call us at (508) 435-4830 or (800) 639-3803

Please include the following information in your email:
 • Where item was purchased
 • Item, model, style or SKU number listed on instructions or box
 • Part number, description of the part and quantity needed
 This information will help us get the proper part to you faster