

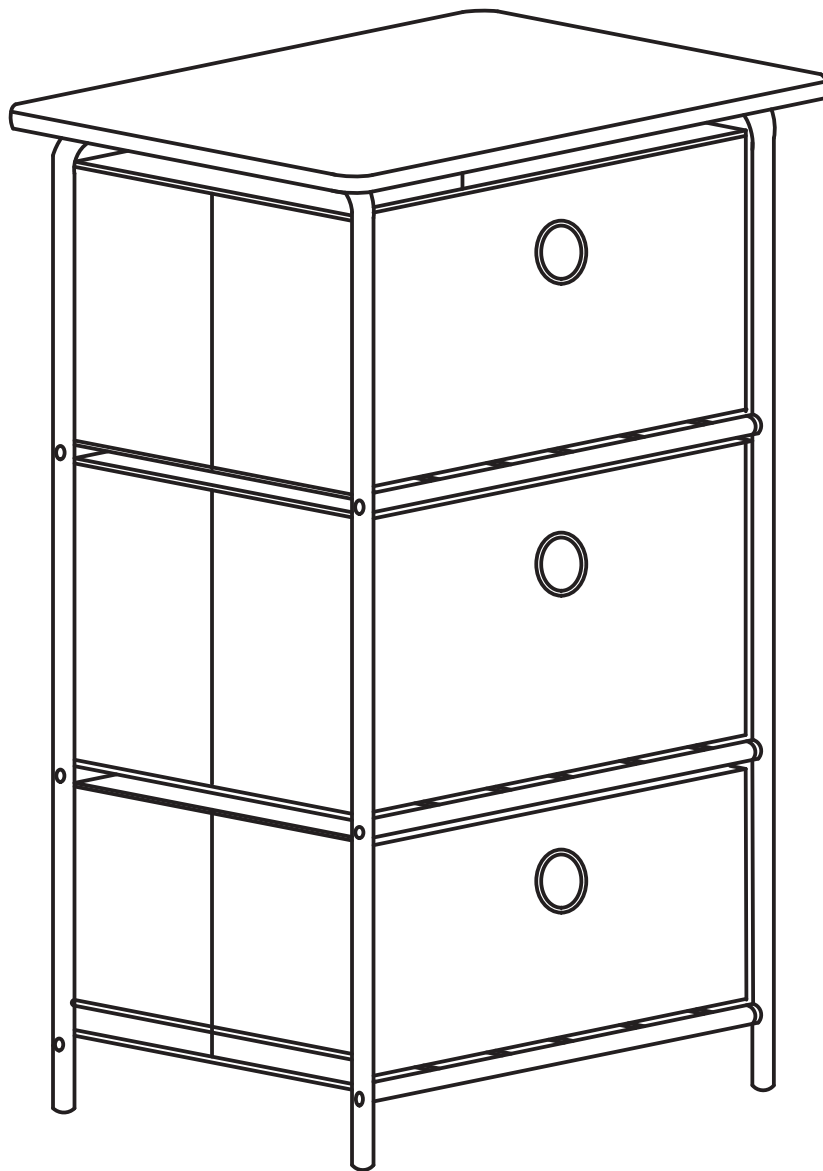











fourstargroup

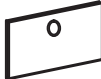

MODEL: 11221427BF

3 BIN STORAGE ORGANIZER

PARTS LIST

NO	HARDWARE LIST	QTY
A	LEG FRAME 	2PCS
B	WIRE SHELF 	3PCS
C	NON-WOVEN BIN 	3PCS
D	BOTTOM BIN SUPPORT 	3PCS
E	TOP PANEL 	1PC
F	METAL WIRE 	2PCS
G	SCREW 	4PCS
H	PLASTIC WASHER 	12PCS
I	BOLT (30 MM) 	12PCS
J	BOLT (12 MM) 	4PCS
K	ALLEN WRENCH 	1PC

CAUTION:

- 1. READ THIS INSTRUCTION MANUAL BEFORE YOU ASSEMBLE.**
- 2. ASSEMBLE ON SOFT SURFACE TO PREVENT DAMAGE TO FINISH OF PRODUCT.**

ASSEMBLY INSTRUCTIONS

STEP 1

ATTACH WIRE SHELF (B) TO LEG FRAMES (A) USING BOLTS (I) AND PLASTIC WASHERS (H) WITH PROVIDED ALLEN WRENCH (K) AS SHOWN.

* DO NOT TIGHTEN THE BOLTS AT THIS TIME.

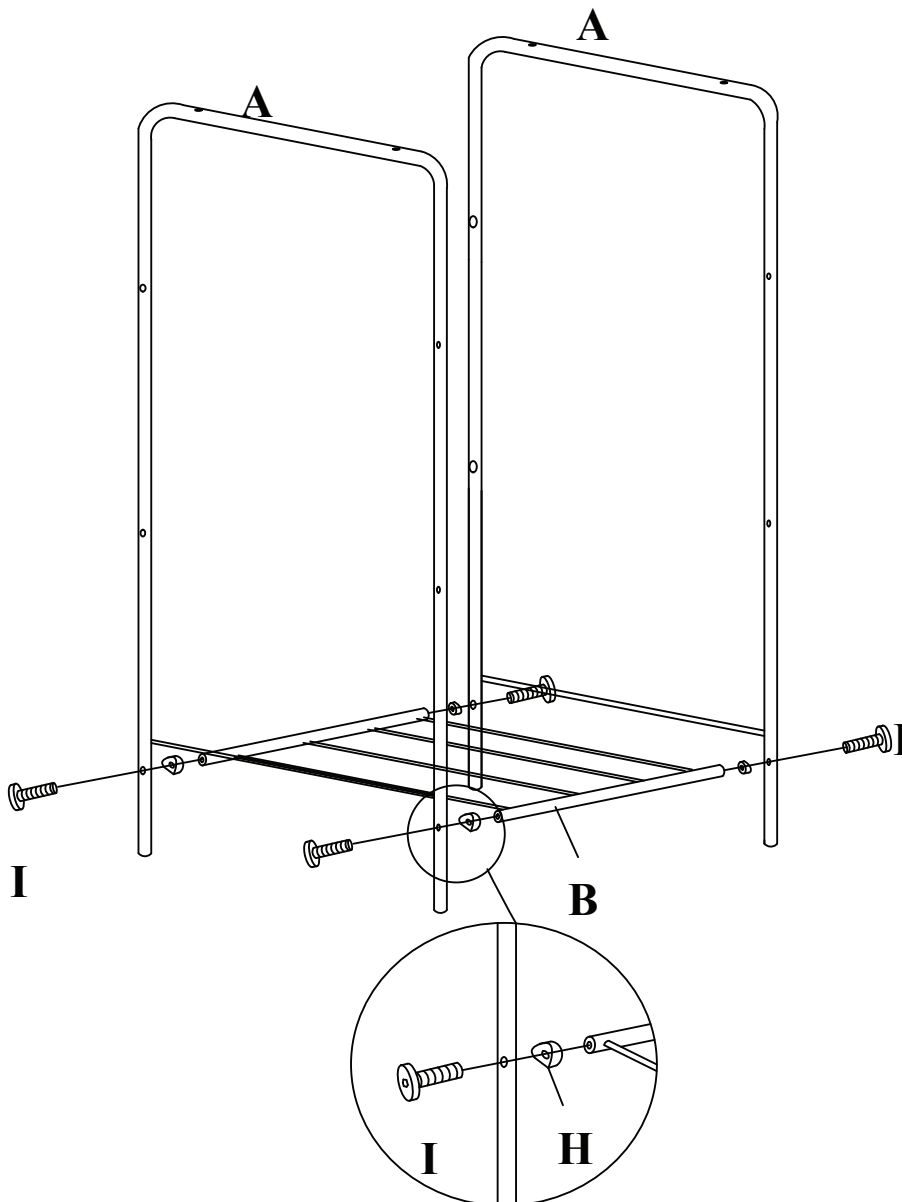

STEP 2

REPEAT STEP 1, ATTACH WIRE SHELF (B) TO LEG FRAMES (A) USING BOLTS (I) AND PLASTIC WASHERS (H) WITH PROVIDED ALLEN WRENCH (K) AS SHOWN.

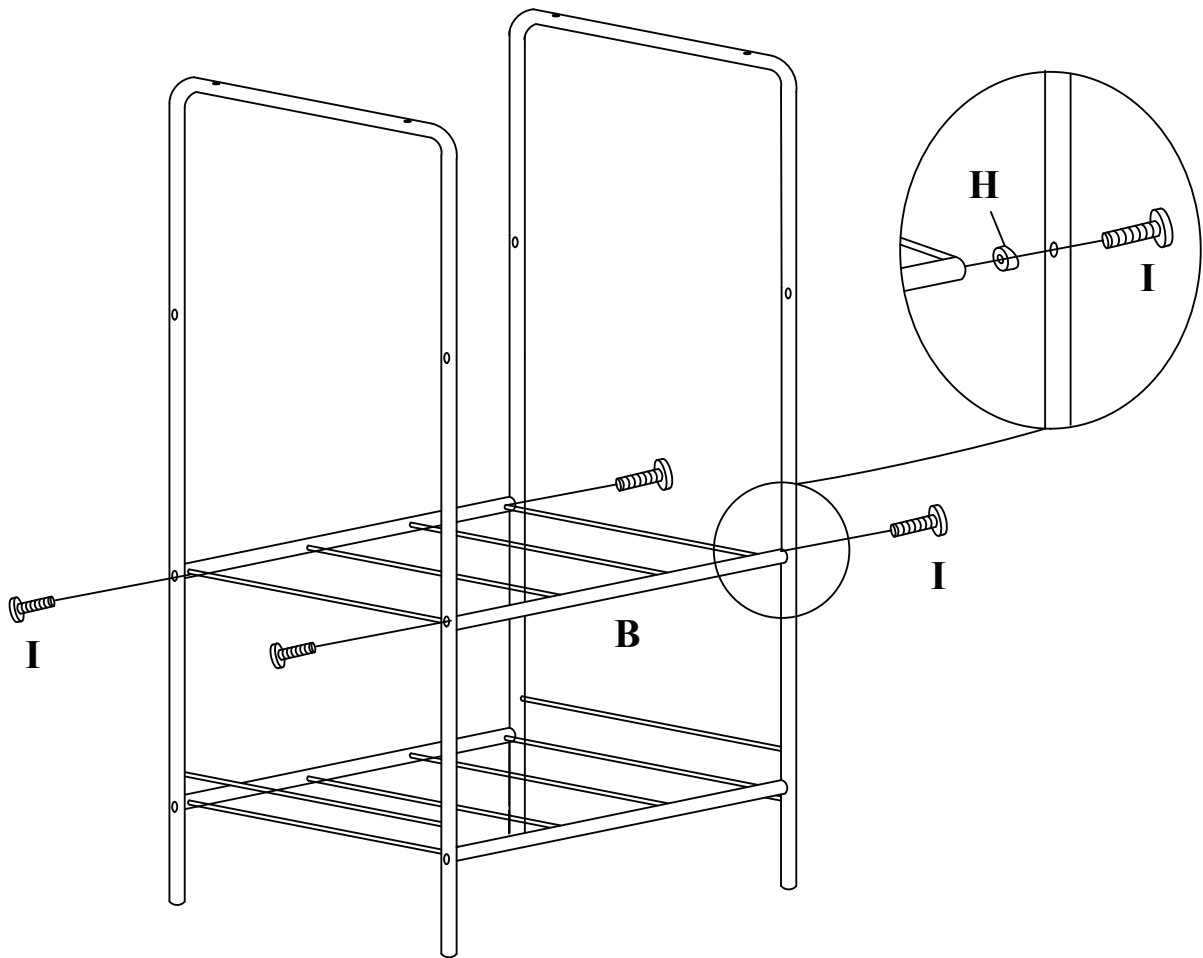

STEP 3

REPEAT STEP 1, ATTACH WIRE SHELF (B) TO LEG FRAMES (A) USING BOLTS (I) AND PLASTIC WASHERS (H) WITH PROVIDED ALLEN WRENCH (K) AS SHOWN.

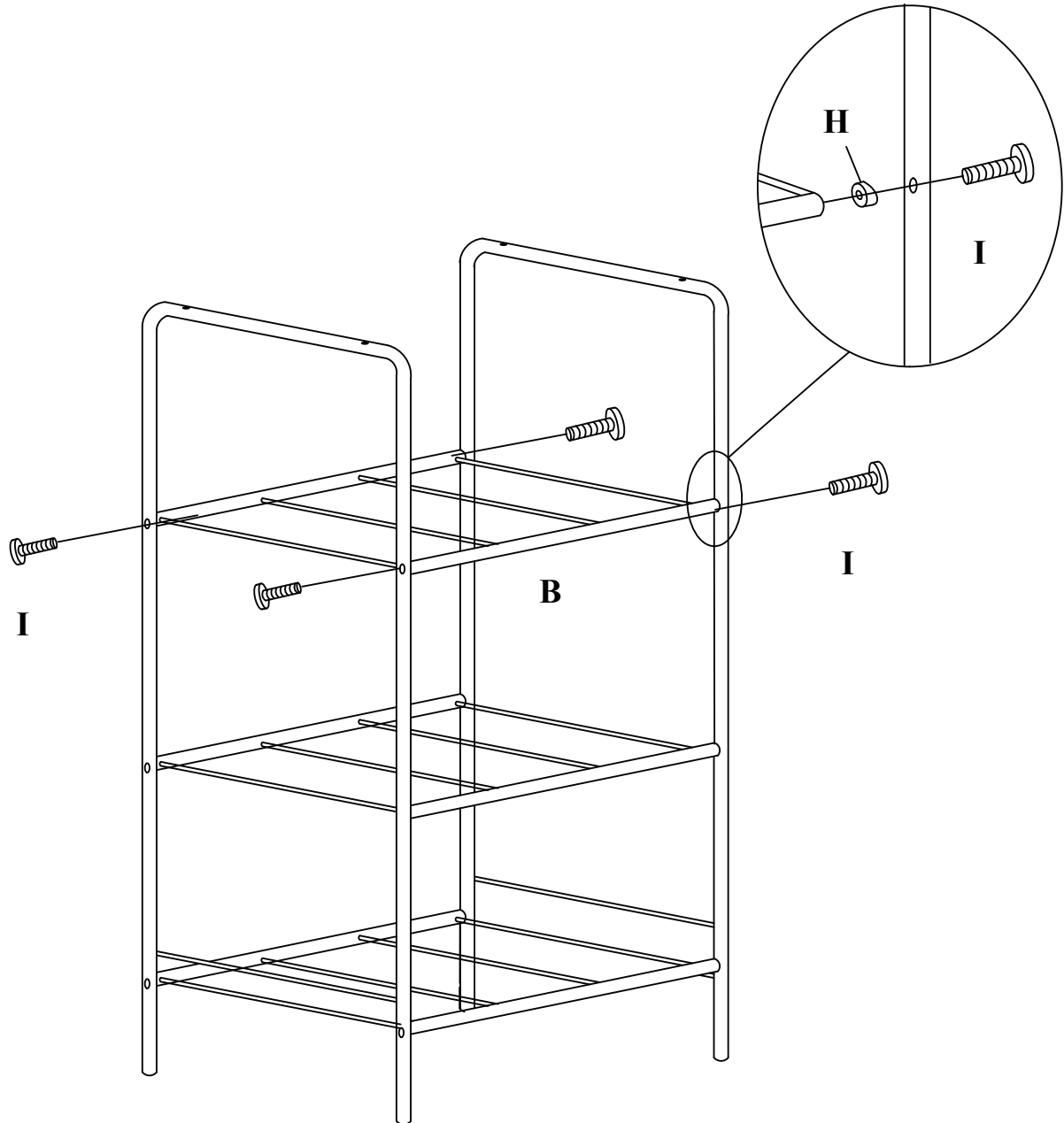

STEP 4
ATTACH METAL WIRES (F)
TO LEG FRAMES (A)
USING BOLTS (J) AS
SHOWN.

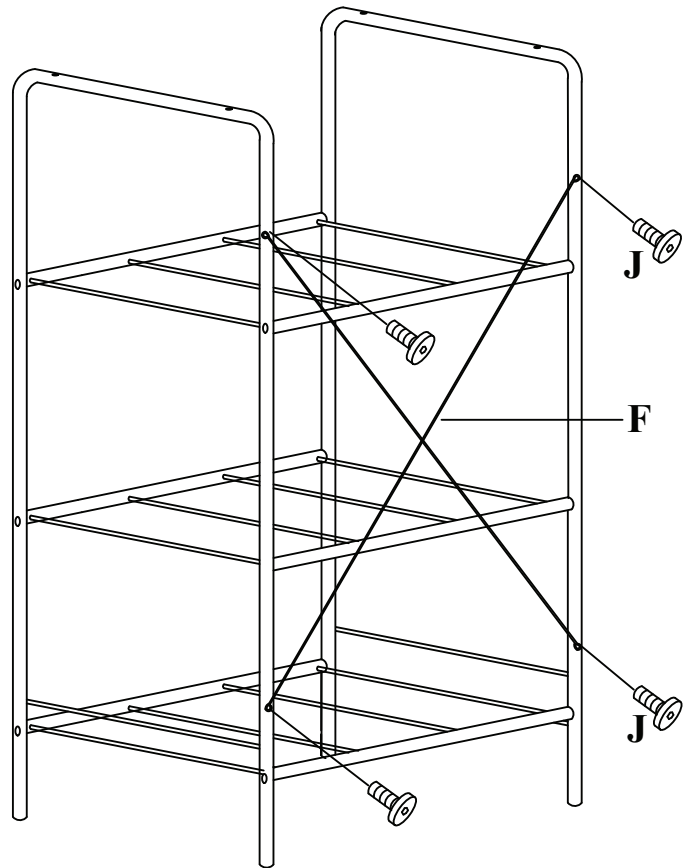

STEP 5
ATTACH LEG FRAMES (A) TO
TOP PANEL (E) USING
SCREWS (G) AS SHOWN.
*** TIGHTEN ALL THE BOLTS**
AT THIS TIME.

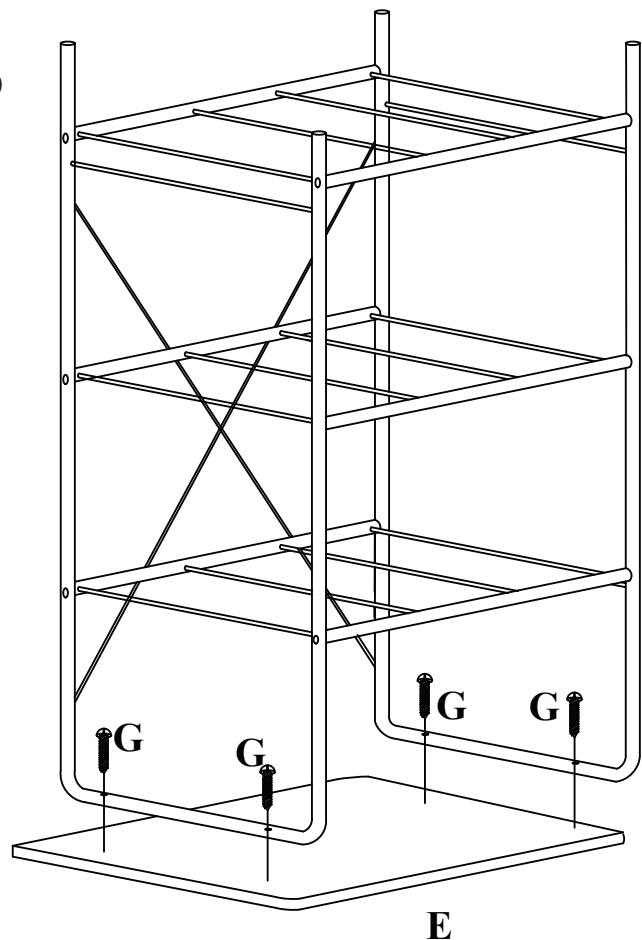

STEP 6

UNFOLD NON-WOVEN BIN (C) AND PUT THE BOTTOM BIN SUPPORT (D) INTO NON-WOVEN BIN (C) AS SHOWN.

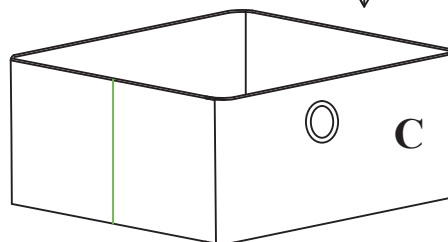
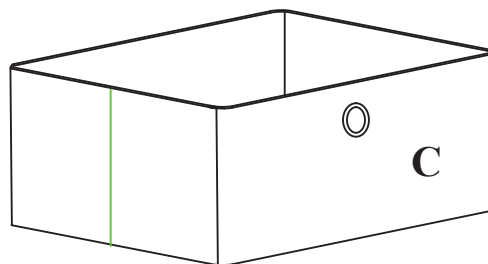
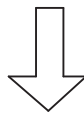
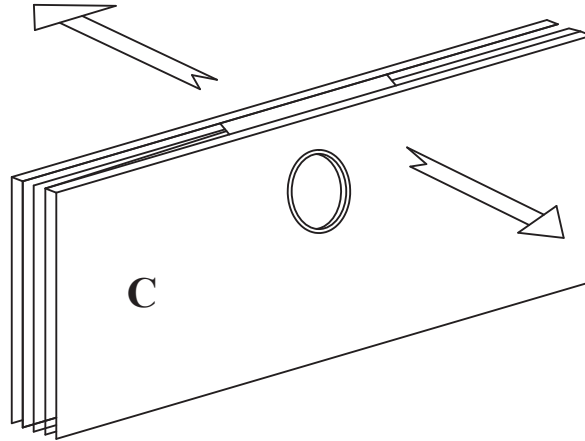

STEP 7

PLACE NON-WOVEN BIN (C) ONTO THE SHELVES AS SHOWN.

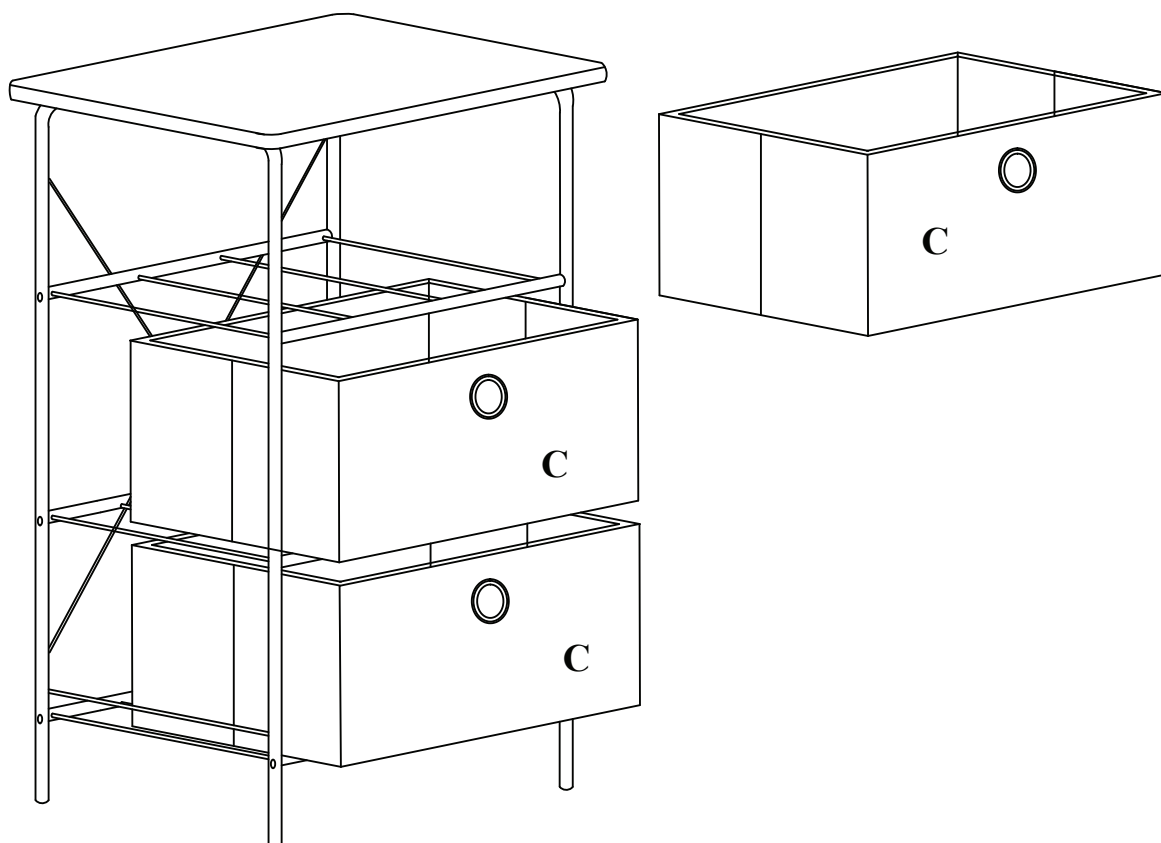

Do you have any questions? Missing small parts or hardware?
If you need assistance with the assembly of your 3 BIN
STORAGE ORGANIZER please e-mail our Customer Service
Department at: support@fourstari.com
or call us at (508) 435-4830
or (800) 639-3803

Please include the following information in your email:

- Where item was purchased
- Item, model, style or SKU number listed on instructions or box
- Part number, description of the part and quantity needed

This information will help us get the proper part to you faster