

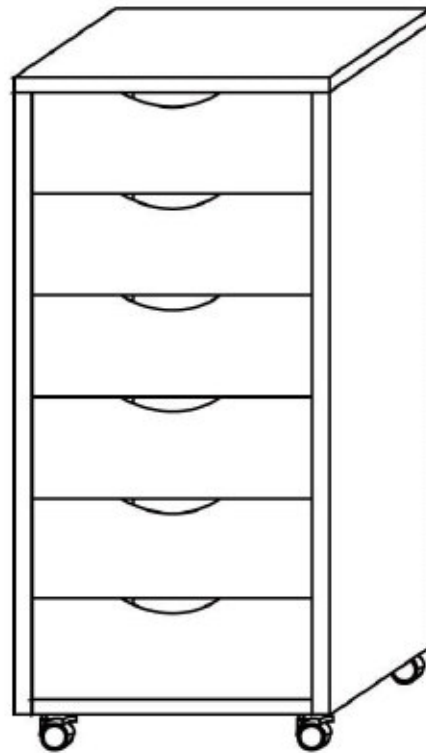



















fourstargroup

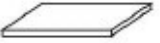

MODEL: 11220942

SIX DRAWER ROLLING CART

PARTS LIST AND HARDWARE

<p>A. WOOD DOWEL 34PCS</p> 	<p>B. WOOD SCREW 12PCS</p> 	<p>C. CAMLOCK 22PCS</p> 
<p>D1. CASTOR WITH LOCK 2PCS</p> 	<p>D2. CASTOR 2PCS</p> 	<p>E. SCREW 16PCS</p> 
<p>F. PIN 14PCS</p> 	<p>① LEFT SIDE PANEL 1PC</p> 	<p>② RIGHT SIDE PANEL 1PC</p> 
<p>③ BOTTLE PANEL 1PC</p> 	<p>④ APRON 1PC</p> 	<p>⑤ TOP PANEL 1PC</p> 
<p>⑥ DRAWER REAR PANEL 6PCS</p> 	<p>⑦ DRAWER LEFT SIDE PANEL 6PCS</p> 	<p>⑧ DRAWER RIGHT SIDE PANEL 6PCS</p> 
<p>⑨ DRAWER BOTTOM PANEL 6PCS</p> 	<p>⑩ DRAWER FRONT PANEL 6PCS</p> 	<p>⑪ REAR PANEL 1PC</p> 

ASSEMBLY INSTRUCTIONS

STEP 1

- 1.1 Attach castors(D1)(D2) to bottom panel(3) using screws(E) as shown.
- 1.2 Attach bottom panel(3) and apron (4) to left side panel(1)and right side panel(2)using wood dowels(A) and camlocks(C) as shown.

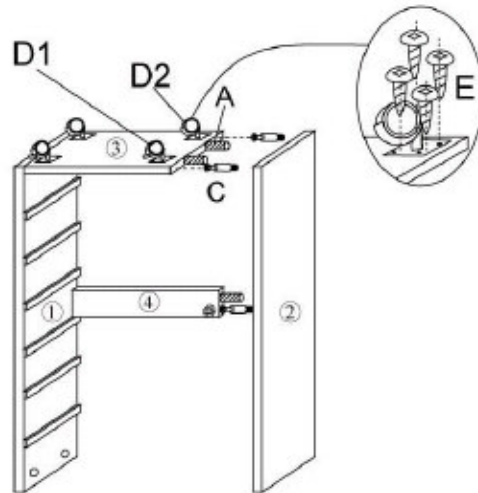

STEP 2

- 2.1 Turn the partially assembled item from Step(1) right-side up.
- 2.2 Attach top panel(5) to each side panel using wood dowels(A) and camlocks (C) as shown.

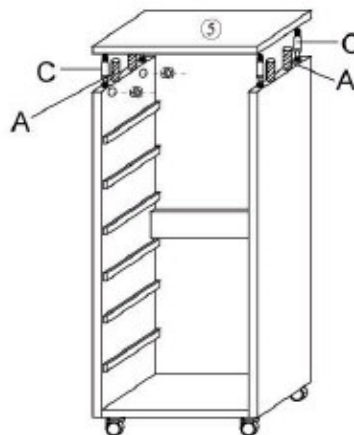

STEP 3

3.1 Attach drawer side panel(7) and(8) to drawer rear panel(6) using wood dowels(A) and wood screw(B), then insert drawer bottom panel ⑨ as shown.

3.2 Attach drawer front panel to each drawer side panels using wood dowel(A) and camlock(C)

3.3 Repeat above step to assemble other drawers.

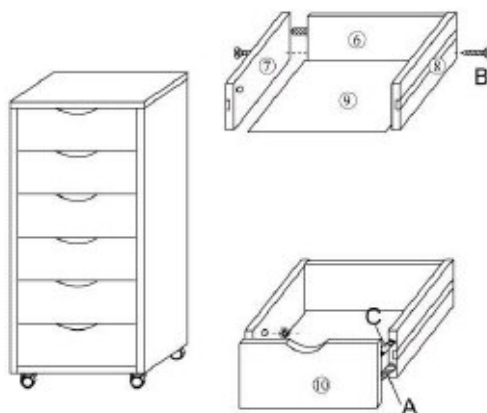

STEP 4

Attach rear panel(11) to cabinet using pin(F) as shown.

STEP 5

Insert assembled drawers into storage cart.

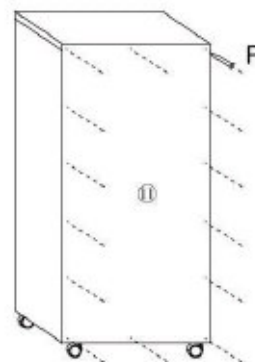

Do you have any questions? Missing small parts or hardware?
If you need assistance with the assembly of your SIX DRAWER ROLLING CART please e-mail our Customer Service Department at:
support@fourstari.com
or call us at (508) 435-4830
or (800) 639-3803

Please include the following information in your email:
• Where item was purchased
• Item, model, style or SKU number listed on instructions or box
• Part number, description of the part and quantity needed
This information will help us get the proper part to you faster