

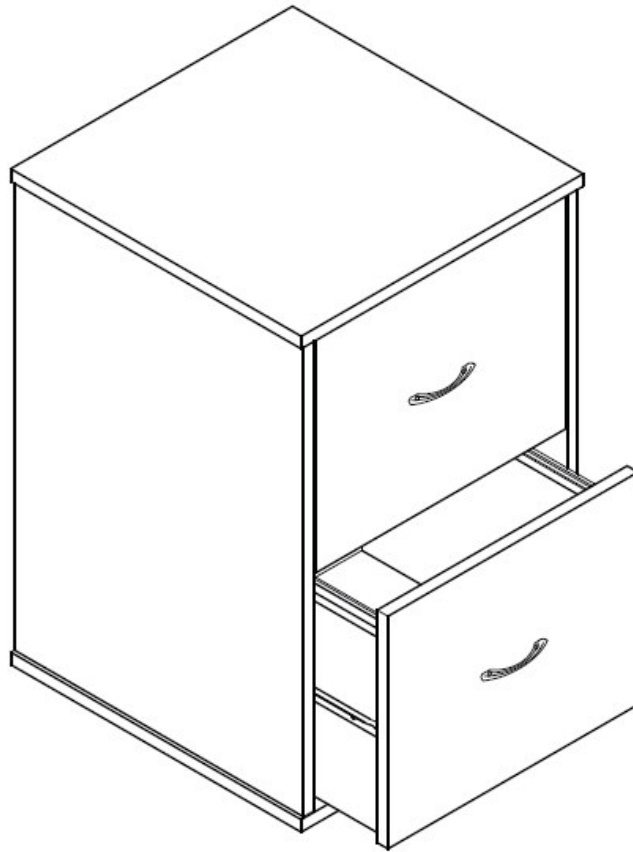











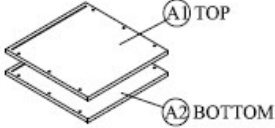

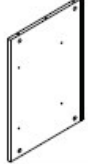

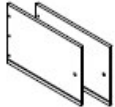
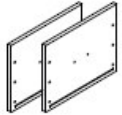

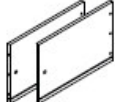
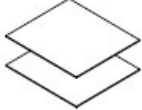



fourstargroup



MODEL: 11219233J

2 DRAWER LETTER FILING CABINET

PARTS LIST AND HARDWARE

<p>A. CABINET TOP PANEL CABINET BOTTOM PANEL</p> 	<p>B. CABINET REAR PANEL X 1PC</p> 	<p>C. CABINET LEFT PANEL X 1PC</p> 
<p>D. CABINET RIGHT PANEL X 1PC</p> 	<p>E. DRAWER RIGHT PANEL X 2PCS</p> 	<p>F. DRAWER FRONT PANEL X 2PCS</p> 
<p>G. DRAWER REAR PANEL X 2PCS</p> 	<p>H. DRAWER LEFT PANEL X 2PCS</p> 	<p>I. DRAWER BOTTOM PANEL X 2PCS</p> 
<p>J. HANDLE X 2PCS</p> 	<p>K. PLASTIC "H" BRACKET X 4PCS</p> 	<p>DL. SLIDING DRAWER SUPPORT X 2PCS (LEFT SIDE)</p> 
<p>DR. SLIDING DRAWER SUPPORT X 2PCS (RIGHT SIDE)</p> 	<p>CL. SLIDING DRAWER SUPPORT X 2PCS (LEFT SIDE)</p> 	<p>CR. SLIDING DRAWER SUPPORT X 2PCS (RIGHT SIDE)</p> 
<p>N. SMALL SCREW X 16PCS</p> 	<p>O. HANDLE SCREW X 4PCS</p> 	<p>P. CAM LOCK X 8PCS</p>  <p>Ø12x11</p>
<p>Q. CAM LOCK SCREW X 16PCS</p> 	<p>R. WOODEN DOWEL X 4PCS</p>  <p>Ø8x30</p>	<p>S. WOODEN DOWEL X 16PCS</p>  <p>Ø6x30</p>
<p>T. CAM LOCK X 8PCS</p>  <p>Ø15x11</p>		

ASSEMBLY INSTRUCTIONS

STEP 1

Using a screwdriver, turn SMALL SCREW (N) to fasten the 2 LEFT SIDE SLIDING CABINET SUPPORTS (CL) to the CABINET LEFT PANEL (C), and the 2 RIGHT SIDE SLIDING CABINET SUPPORTS (CR) to the CABINET RIGHT PANEL (D).

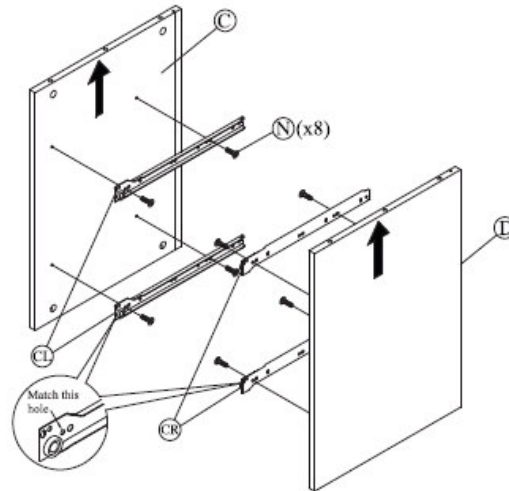

STEP 2

- *Using a screwdriver, thread CAM LOCK SCREWS (Q) and WOODEN DOWEL (R) into holes on CABINET BOTTOM PANEL (A2).
- *Attach CABINET BOTTOM PANEL (A2) to the CABINET LEFT AND RIGHT PANELS (C&D) by inserting CAM LOCK SCREWS (Q) into holes on the bottom of the 2 side panels.
- *Insert CAM LOCKS (T) into holes in the bottom of the CABINET LEFT AND RIGHT PANELS (C&D) with phillips slot facing out.
- *Using a screwdriver, turn CAM LOCKS (T) clockwise to tighten CABINET BOTTOM PANEL (A2) to CABINET LEFT AND RIGHT PANELS (C&D).
- *Slide CABINET REAR PANEL (B) into the grooves on the CABINET LEFT AND RIGHT PANELS (C&D).

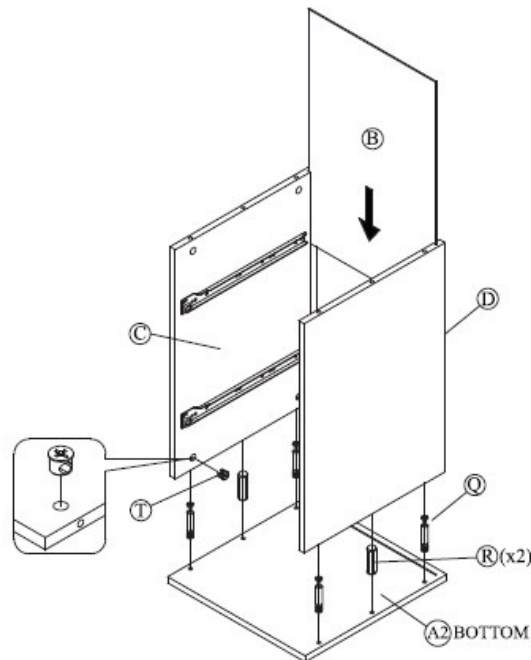

STEP 3

- * Using a screwdriver, thread CAM LOCK SCREWS (Q) and WOODEN DOWEL (R) into CABINET TOP PANEL (A1).
- * Attach CABINET TOP PANEL (A1) to the CABINET LEFT AND RIGHT PANELS (C&D) by inserting CAM LOCK SCREWS (Q) into holes on the top of the 2 side panels.
- * Insert CAM LOCKS (T) into holes in the top of the CABINET LEFT AND RIGHT PANELS (C&D) with phillips slot facing out.
- * Using a screwdriver, turn CAM LOCKS (T) clockwise to tighten CABINET TOP PANEL (A1) to CABINET LEFT AND RIGHT PANELS (C&D).

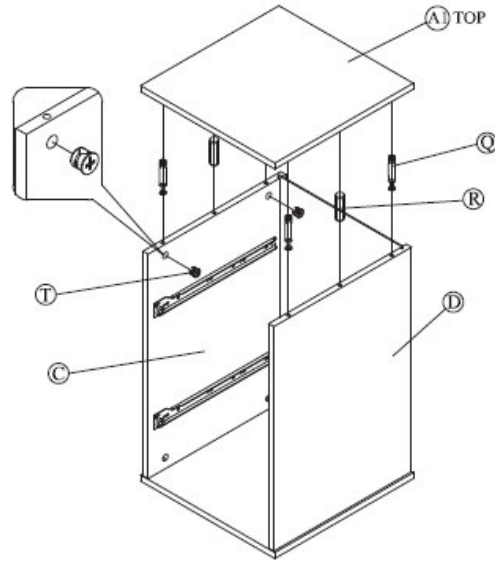

STEP 4

- * Using a screwdriver, thread CAM LOCK SCREWS (Q) into DRAWER LEFT AND RIGHT PANELS (H&E).
- * Insert WOOD DOWELS (S) into the top and bottom holes in back edge of DRAWER LEFT AND RIGHT PANELS (H&E).
- * Attach DRAWER LEFT AND RIGHT PANELS (H&E) to DRAWER REAR PANEL (G) by aligning WOOD DOWELS (S) and CAM LOCK SCREWS (Q) with holes in side edges of DRAWER REAR PANEL (G).
- * Insert CAM LOCKS (P) into holes in front of DRAWER REAR PANEL (G) and tighten with a screwdriver.
- * Repeat steps 4-7 for another drawer.

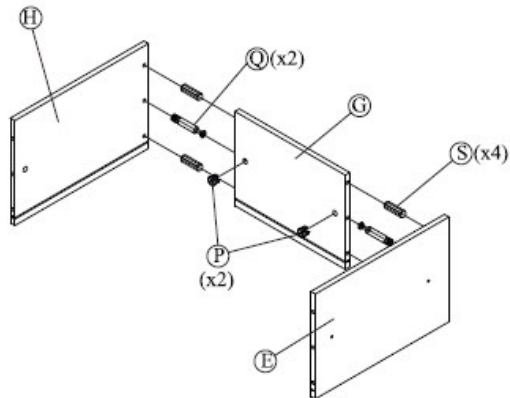

STEP 5

*Slide DRAWER BOTTOM PANEL (I) into the slots as shown.

Attach LEFT SIDE SLIDING DRAWER SUPPORT (DL) with 2 SMALL SCREWS (N) to the outside of DRAWER LEFT PANEL (H).

Attach RIGHT SIDE SLIDING DRAWER SUPPORT (DR) with 2 SMALL SCREWS (N) to the outside of DRAWER RIGHT PANEL (E).

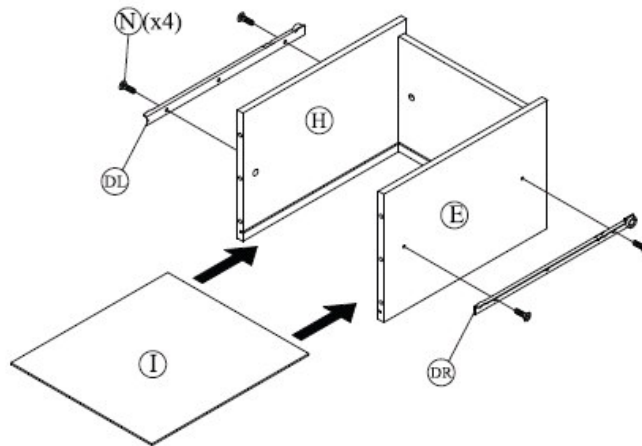

STEP 6

*Attach HANDLE (J) to DRAWER FRONT PANEL (F) with 2 HANDLE SCREWS (O).

*Thread 2 CAM LOCK SCREWS (Q) into the center holes on each side in the back of DRAWER FRONT PANEL (F).

*Insert four WOOD DOWELS (S) into holes above and below CAM LOCK SCREWS (Q).

*Align WOOD DOWELS (S) and CAM LOCK SCREWS (Q) with holes in drawer assembled in step 6 to attach DRAWER FRONT PANEL (F).

* Insert CAM LOCKS (P) into DRAWER LEFT AND RIGHT PANELS (H&E) and tighten.

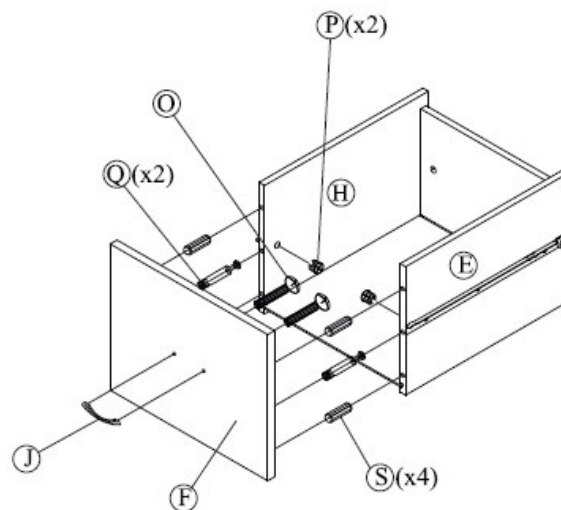

STEP 7

*Slide one PLASTIC "H" BRACKET (K) onto the top of each side panel with the high edge to the inside.

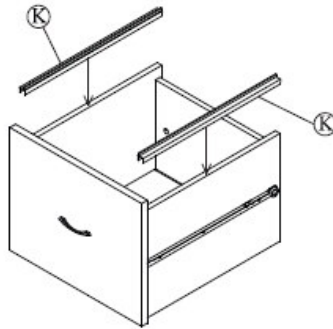

STEP 8

*Align drawer slides on assembled drawer with drawer slides on assembled cabinet.

*Slide assembled drawer to assembled cabinet.

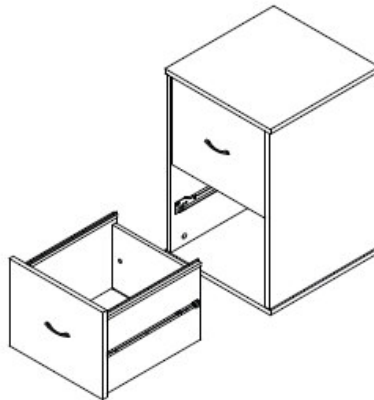

Do you have any questions ? Missing small parts or hardware ?
If you need assistance with the assembly of your 2 DRAWER
LETTER FILING CABINET please e-mail our Customer Service
Department at:
support@fourstari.com
or call us at **(508) 435-4830**
or (800) 639-3803

Please include the following information in your email:

- Where item was purchased
- Item, model, style or SKU number listed on instructions or box
- Part number, description of the part and quantity needed

This information will help us get the proper part to you faster