

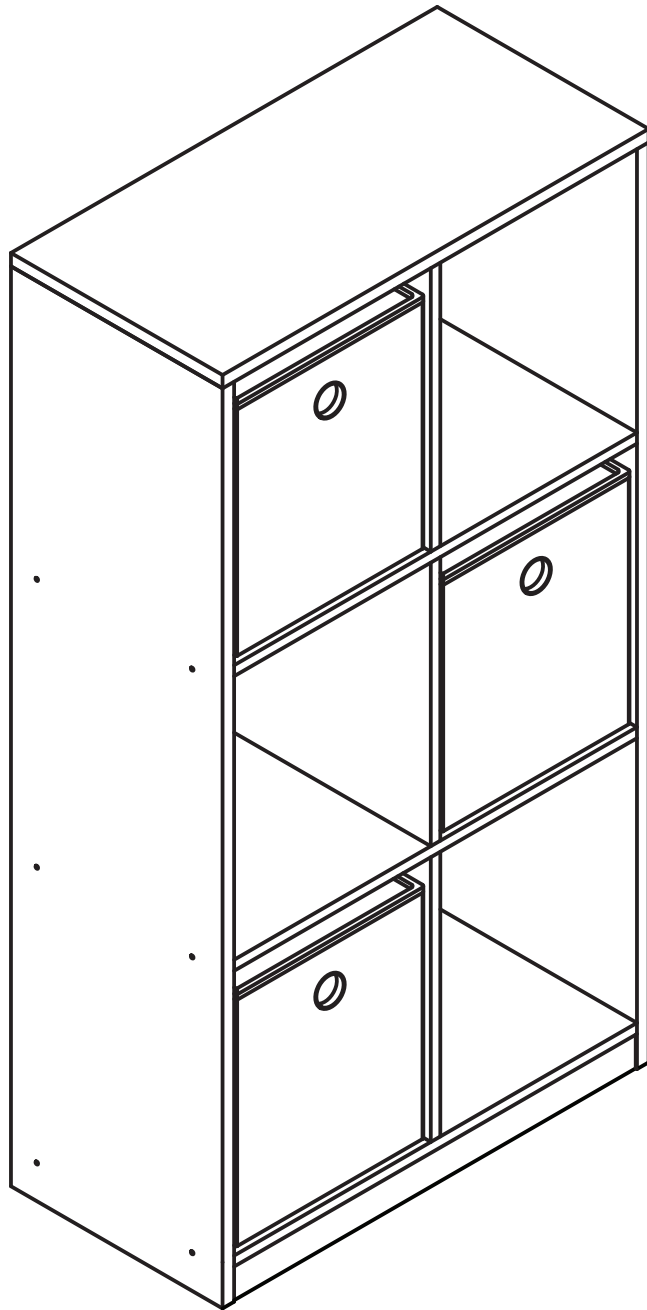

fourstargroup







MODEL: 11210931

**STORAGE ORGANIZER**

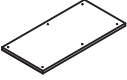
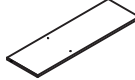
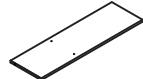
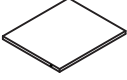
# PARTS LIST AND HARDWARE

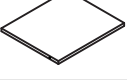
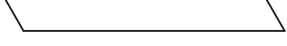
NO	HARDWARE LIST		QTY
1	SCREW M4 x 38mm (BLACK)		12 PCS
2	SCREW M3 x 9mm		4 PCS
3	WOODEN DOWEL M6 x 30mm		4 PCS
4	PLASTIC DOWEL M5 x 20mm		12 PCS
5	L-BRAKET		2 PCS
6	POWER PIN		16 PCS
7	WHITE GLUE		1 PC
8	BIN		3 PCS

NO	PARTS LIST		QTY
A	TOP PANEL		1 PC
B	LEFT SIDE PANEL		1 PC
C	RIGHT SIDE PANEL		1 PC
D	SHELF PANEL		1 PCS
E	CENTER PANEL		3 PCS
F	BOTTOM PANEL		1 PC
G	SHELF PANEL		1 PC
H	BACK PANEL		2 PCS
I	BOTTOM CROSS BAR		1 PC

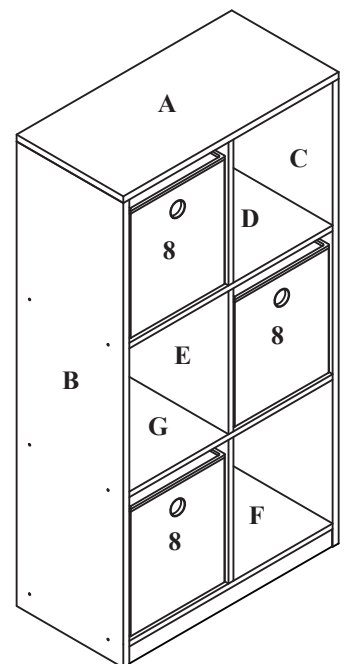

**BEFORE YOU BEGIN, PLEASE FOLLOW ASSEMBLY INSTRUCTIONS CAREFULLY. FOLLOW THEM STEP BY STEP.**

**CAUTION:**

- 1. ADULT SUPERVISION IS REQUIRED DUE TO SMALL PARTS. CARE SHOULD BE TAKEN IN THE UNPACKING AND ASSEMBLY OF THE PRODUCT.**
- 2. ASSEMBLE ON SOFT SURFACES TO PREVENT DAMAGE TO THE PRODUCT FINISH.**
- 3. MAKE SURE ALL PARTS ARE INCLUDED BEFORE ASSEMBLY.**

**ASSEMBLY TOOLS REQUIRED**

**RUBBER MALLET**

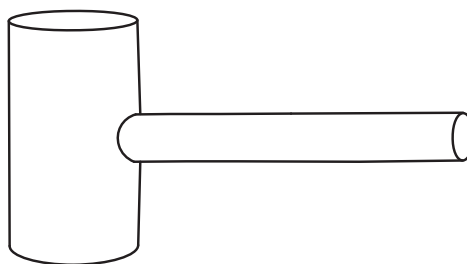

**PHILIPS  
SCREWDRIVER**

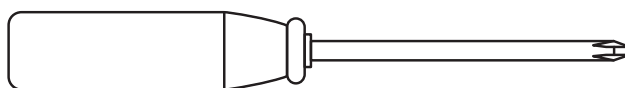

# ASSEMBLY INSTRUCTIONS

## STEP 1

1.1 INSTALL THE PLASTIC DOWEL (4) TO THE CENTER PANEL (E) USING THE GLUE (7), AS SHOWN.

1.2 INSTALL THE WOODEN DOWEL (3) TO THE SIDE PANELS (B & C) USING THE GLUE (7), AS SHOWN.

1.3 INSTALL THE L-BRACKET (5) TO THE BOTTOM PANEL (F) AND BOTTOM CROSSBAR (I) USING THE SCREWS (2), AS SHOWN.

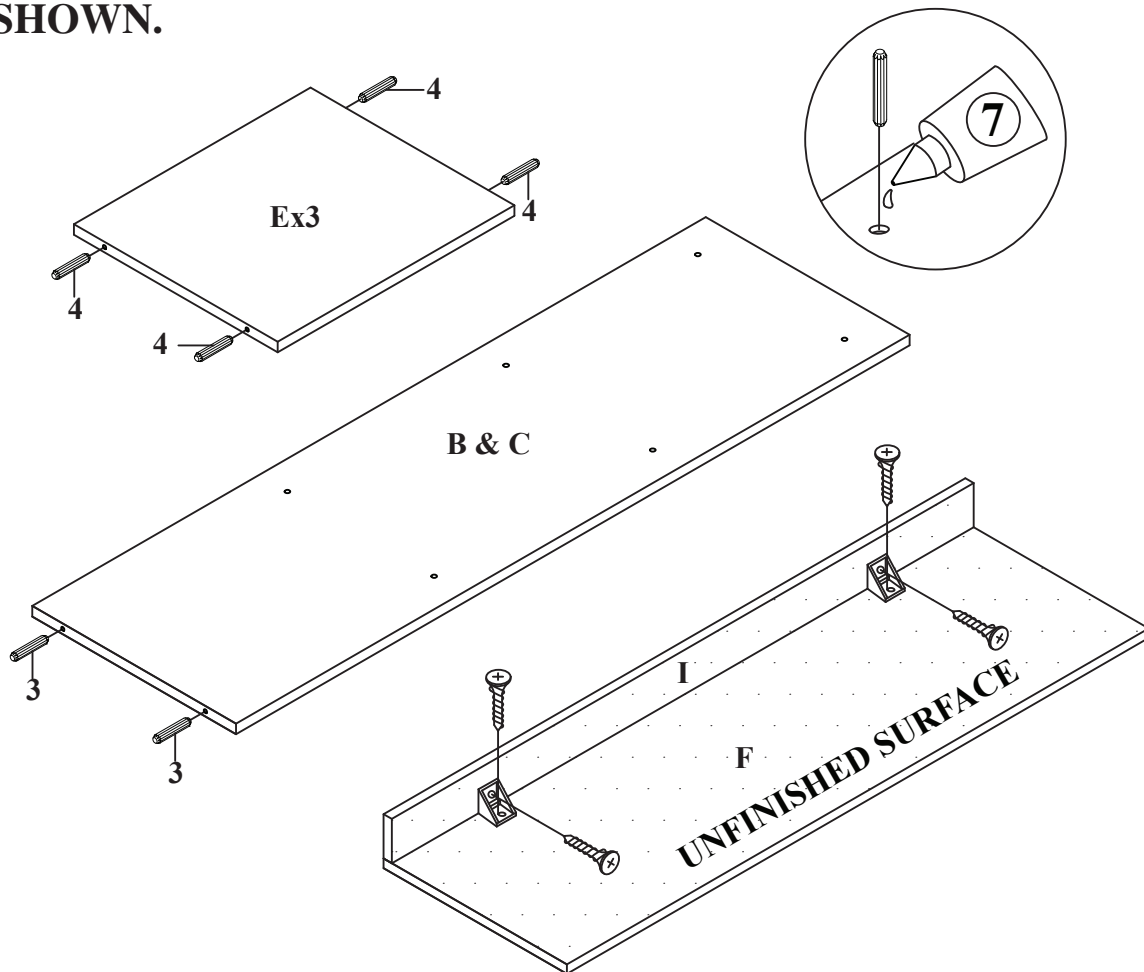

 ② SCREW - 4 PCS

 ⑤ L-BRAKET - 2 PCS

 ⑦ WHITE GLUE - 1 PC

 ③ WOODEN DOWEL M6 x 30mm - 4 PCS

 ④ PLASTIC DOWEL M5 x 20mm - 16 PCS

**STEP 2**

**ATTACH THE CENTER PANELS (E) TO THE SHELF PANELS (D & G) USING THE GLUE (7), AS SHOWN.**

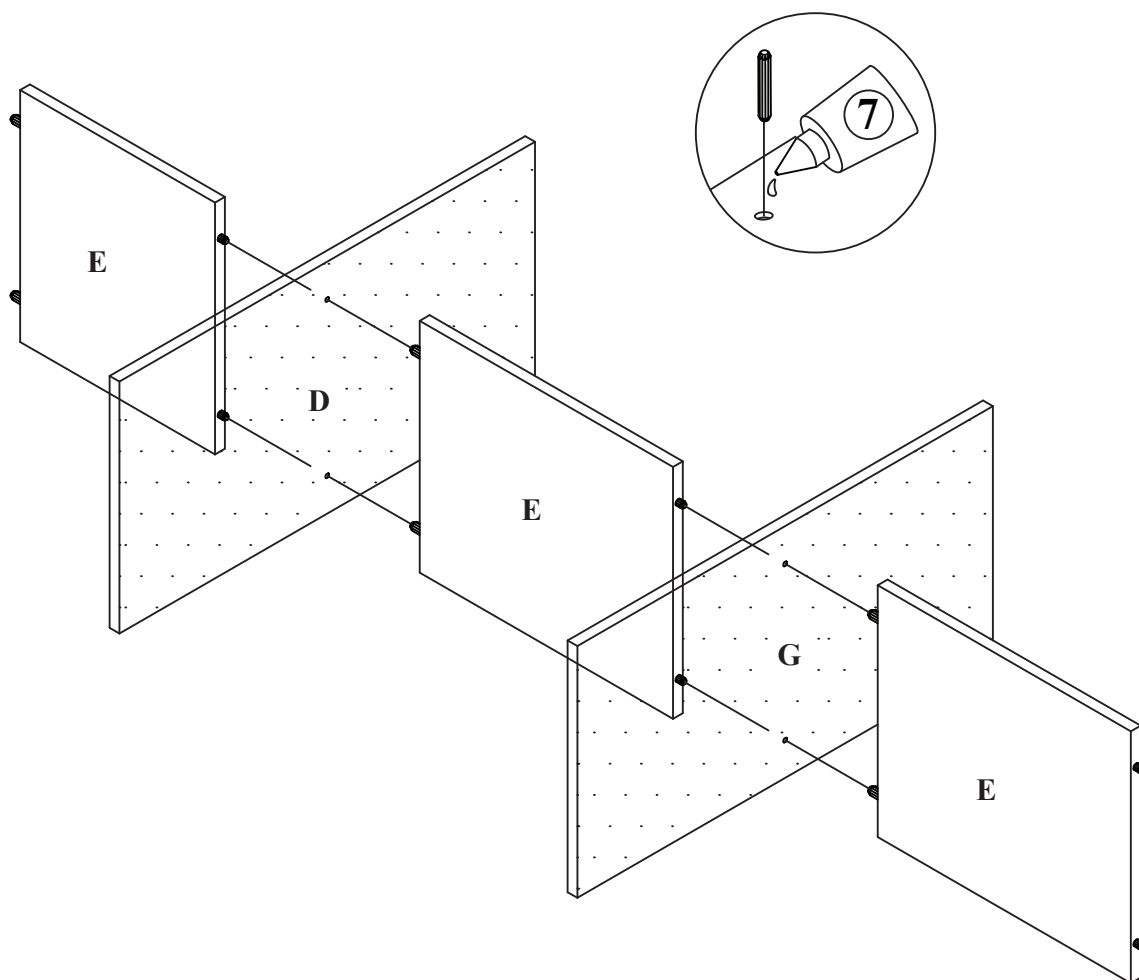

**⑦ WHITE GLUE - 1 PC**

### STEP 3

ATTACH THE SIDE PANELS (B & C) AND THE BOTTOM PANEL (F) TO THE ASSEMBLED PARTS FROM STEP 2 USING THE SCREWS (1), AS SHOWN.

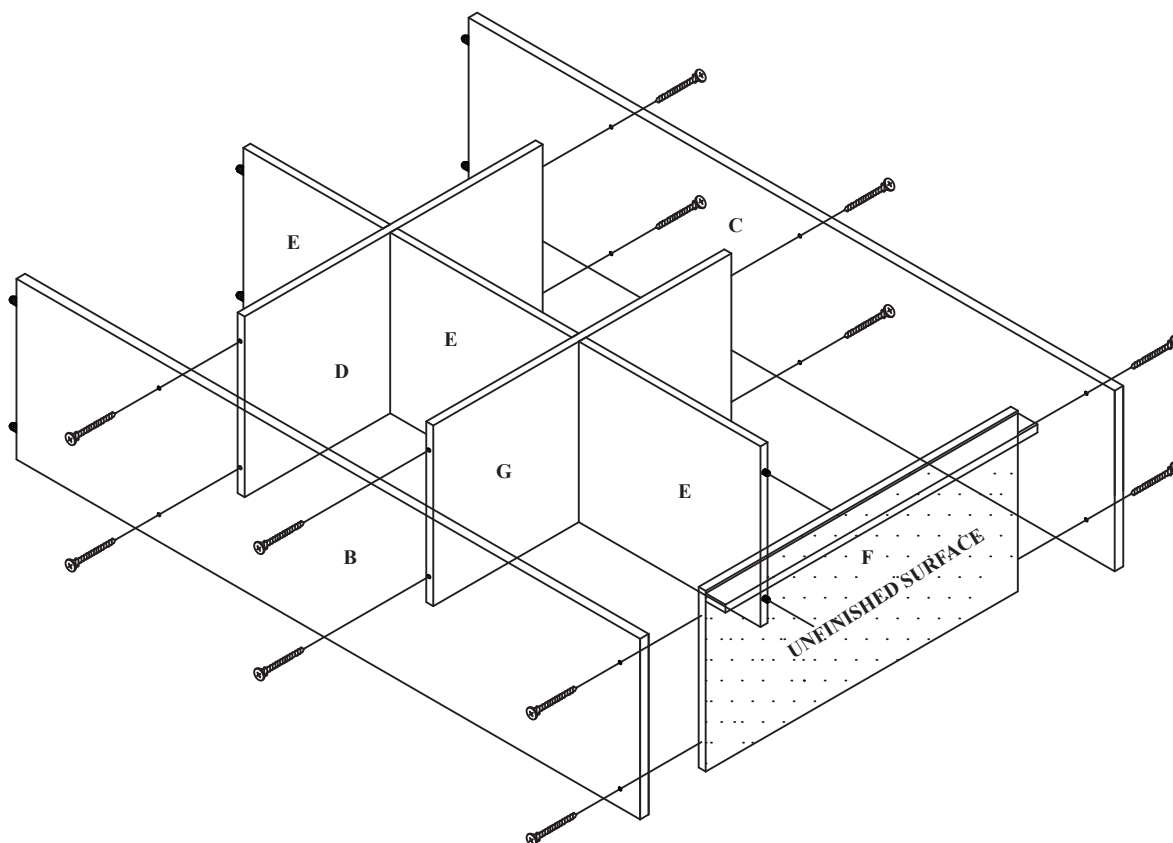

① SCREW M4 x 38mm - 12 PCS

**STEP 4**

**ATTACH THE TOP PANEL (A) TO THE ASSEMBLED PARTS FROM STEP 3 USING THE GLUE (7), AS SHOWN.**

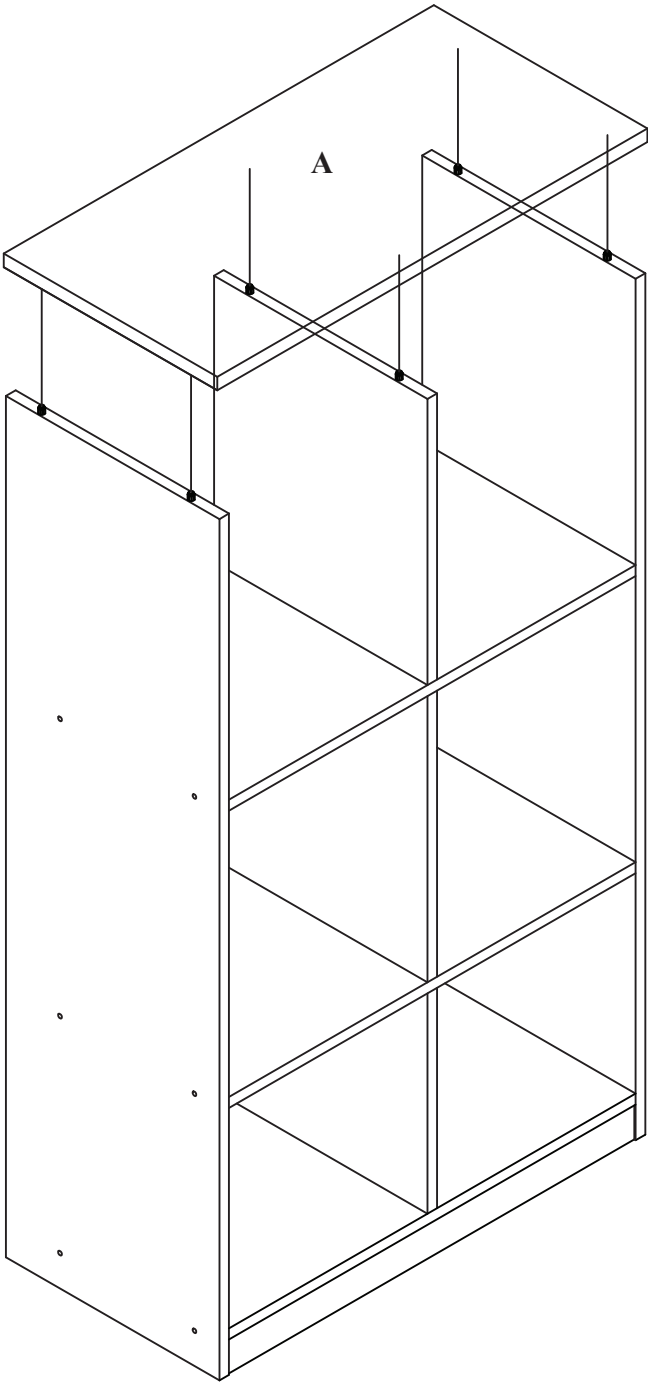
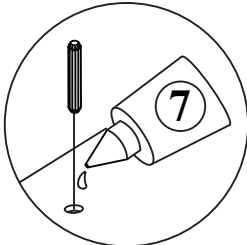

**STEP 5**

**ATTACH THE BACK PANELS (H) USING THE POWER PIN (6) AS SHOWN.**

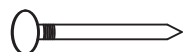
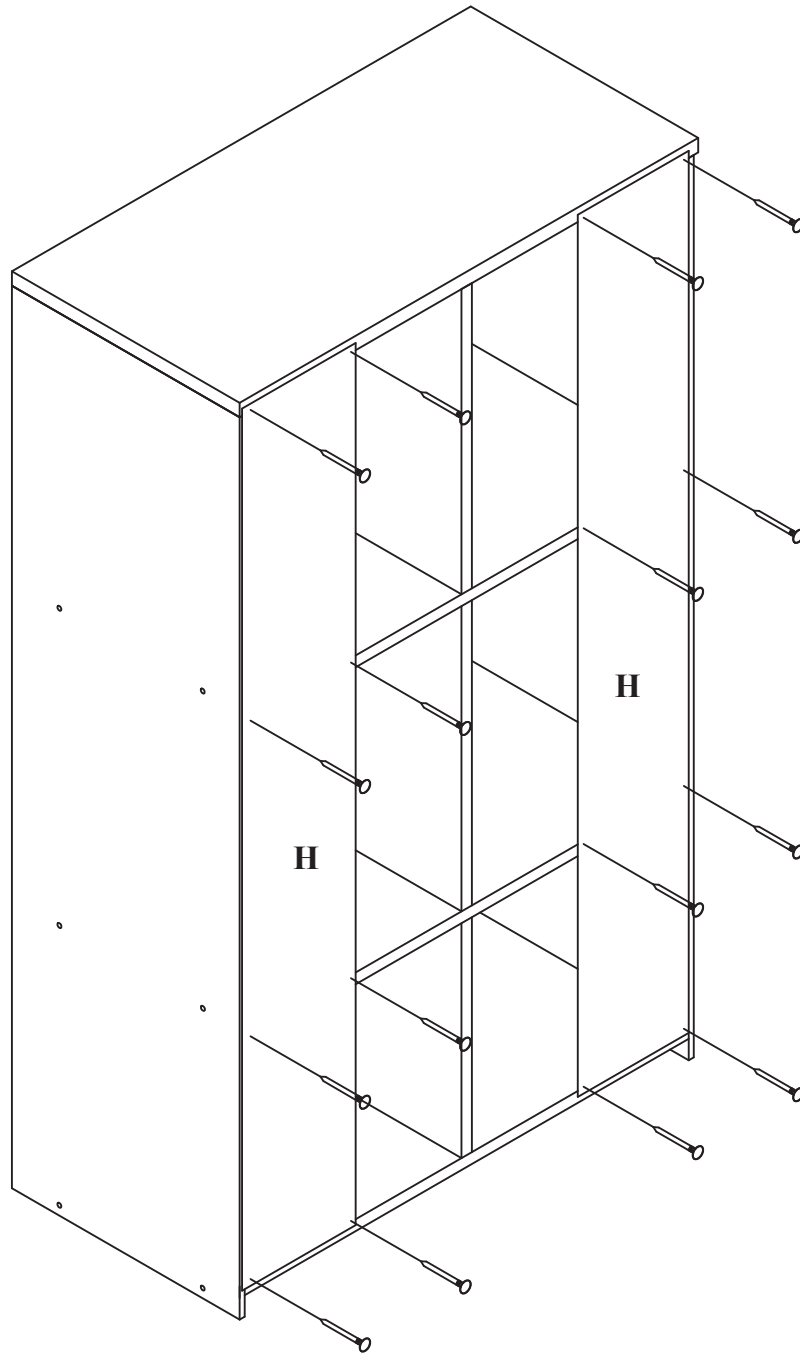

**⑥ POWER PIN - 16 PCS**



**STEP 6**  
**INSERT THE BINS (8).**

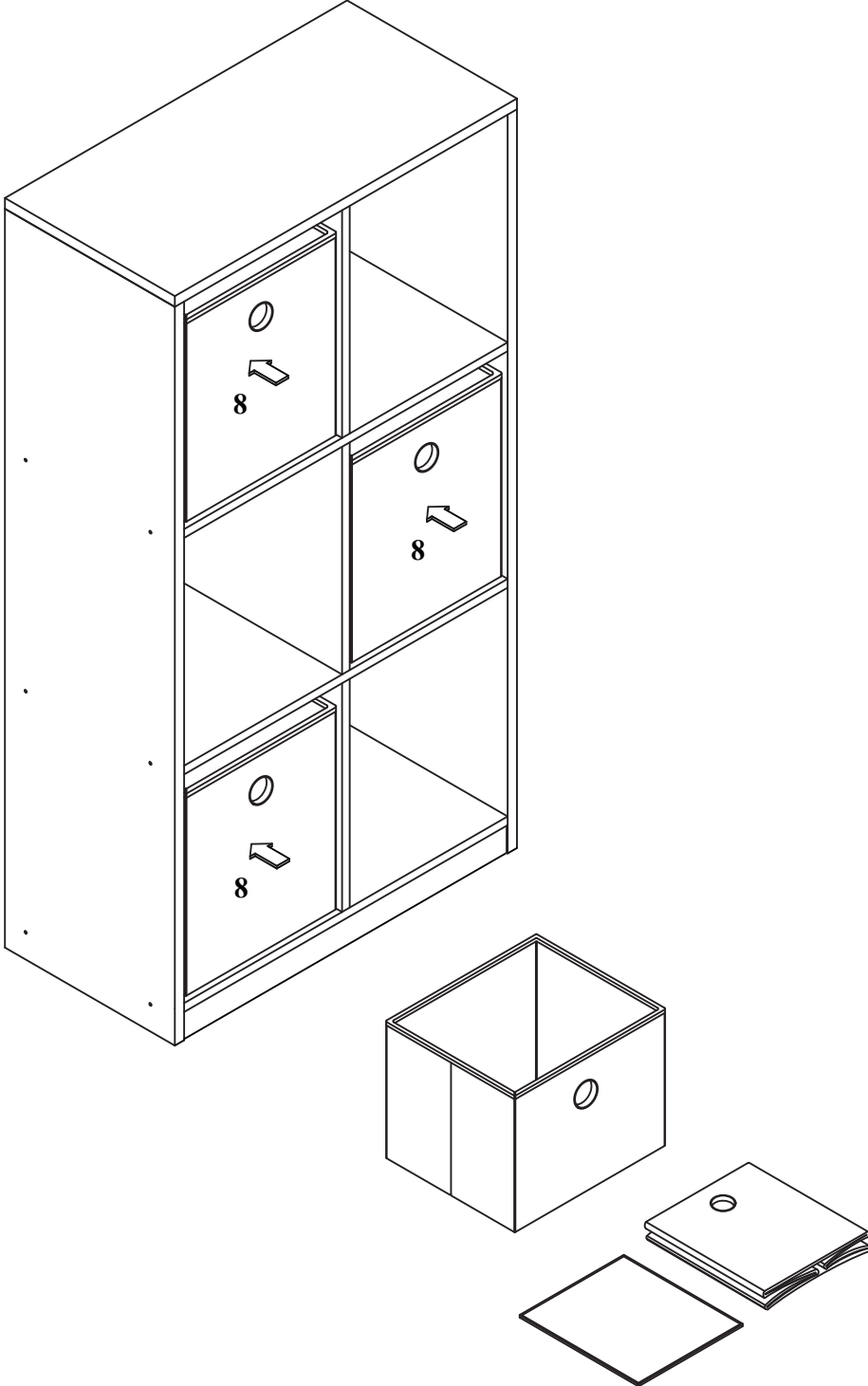

**⑧ BIN - 3 PCS**

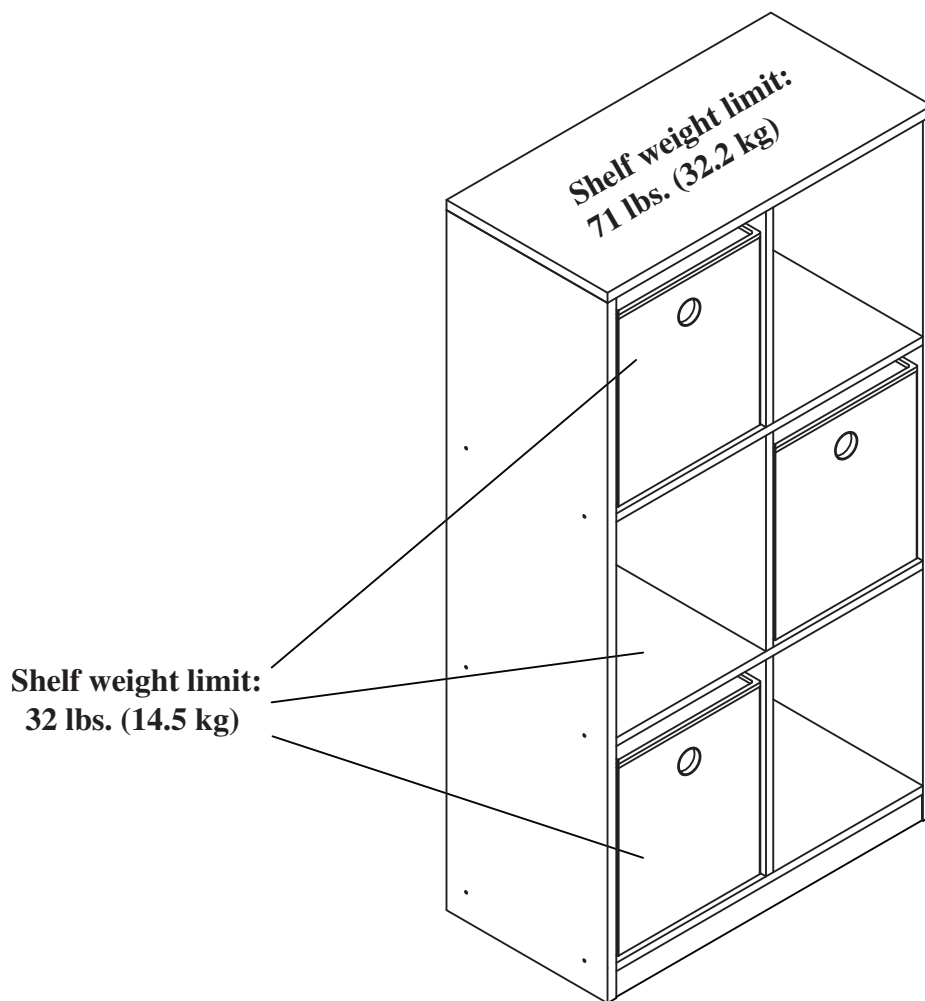

This unit is intended for use only with the products and maximum weights indicated. Use with other products or products heavier than the maximum weights indicated may result in instability causing possible injury. Furniture can tip over or break if improperly moved. Have a friend help to lift and carry the unit to its new location.

Do you have any questions? Missing small parts or hardware?  
If you need assistance with the assembly of your STORAGE ORGANIZER please e-mail our Customer Service Department at: [support@fourstari.com](mailto:support@fourstari.com) or call us at (508) 435-4830 or (800) 639-3803

Please include the following information in your email:

- Where item was purchased
- Item, model, style or SKU number listed on instructions or box
- Part number, description of the part and quantity needed

This information will help us get the proper part to you faster